



Important suggestions to examiners:

- 1) The answers should be examined by key words and not as word-to-word as given in the model answer scheme.
- 2) The model answer and the answer written by candidate may vary but the examiner may try to assess the understanding level of the candidate.
- 3) The language errors such as grammatical, spelling errors should not be given more importance. (Not applicable for subject English and communication skills)
- 4) While assessing figures, examiner may give credit for principle components indicated in a figure. The figures drawn by candidate and model answer may vary. The examiner may give credit for any equivalent figure drawn.
- 5) Credits may be given step wise for numerical problems. In some cases, the assumed constant values may vary and there may be some difference in the candidate's answers and model answer.
- 6) In case some questions credit may be given by judgment on part of examiner of relevant answer based on candidate understands.
- 7) For programming language papers, credit may be given to any other program based on equivalent concept.

Q.1 A)	Attempt any three :	(3x4=12)
a)	State the factors governing selection of electric motors.	
Ans:	<u>Following Factors governing / or are considered while selecting electric drive (Motor) for particular application:</u> (Any Four factor expected: 1 Mark each ,Total 4 Marks)	
	1. <u>Nature of supply:</u> Whether supply available is <ul style="list-style-type: none">➤ AC,➤ Pure DC➤ Or Rectified DC	
	2. <u>Nature of Drive (Motor):</u> Whether motor is used to drive (run) <ul style="list-style-type: none">➤ Individual machine➤ OR group of machines.	
	3. <u>Nature of load:</u> Whether load required light or heavy starting torque <ul style="list-style-type: none">➤ OR load having high inertia, require high starting torque for long duration.➤ OR Whether load torque increases with speed ($T \propto N$)➤ OR decreases with speed ($T \propto 1/N$)➤ OR remains constant with speed ($T = N$)	



	<p>➤ OR increases with square of speed ($T \propto N^2$)</p> <p>4. <u>Electric Characteristics of drive:</u></p> <ul style="list-style-type: none">➤ Starting,➤ Running,➤ Speed control➤ and braking characteristics <p>of electric drive should be studied and it should be matched with load requirements(i.e. machine).</p> <p>5. <u>Size and rating of motor:</u></p> <ul style="list-style-type: none">➤ Whether motor is short time running➤ OR continuously running➤ OR intermittently running➤ OR used for variable load cycle. <p>Whether overload capacity, pull out torque is sufficient.</p> <p>6. <u>Mechanical Considerations:</u></p> <ul style="list-style-type: none">➤ Types of enclosure,➤ Types of bearing,➤ Transmission of mechanical power,➤ Noise➤ and load equalization <p>7. <u>Cost:</u></p> <ul style="list-style-type: none">➤ Capital,➤ Running➤ And maintenance cost should be less.
b)	State four advantages of electric heating.
Ans:	Advantages of Electric heating: (Any Four Advantages expected : 1 Mark each, Total 4 Marks) <ol style="list-style-type: none">1. It can be put into service immediately.2. No standby losses.3. High efficiency.4. More economical than other conventional types of heating system.5. Easy to operate and control.



	<ol style="list-style-type: none">6. No air pollution.7. System is clean, as there is no waste produced.8. No fuel transportation cost.9. No space is required for storage of fuel and waste.10. Noiseless operation.11. Uniform heating is possible; heating at particular point is also possible.12. Dielectric material can be heated.13. Electrical heating equipments are generally automatic, so it requires low attention and supervision.14. Protection against overheating can be provided by suitable switch gear.
c)	Explain the factors to be considered while designing a lighting scheme.
Ans:	Following factors to be considered while designing a lighting scheme (Any Four factors are expected : 1 Mark each, Total 4 Marks) <ol style="list-style-type: none">1. Design of illumination scheme should be very simple.2. Area of the working plane.3. Find out application of working plane4. Decided lux level on working plane as per application.(Illumination level)5. Find out total lumens required on working plane.6. Decide the type and wattage of lamp which is to be used for that particular application7. Quality of light8. Assume waste light Factor9. Assume utilization Factor10. Assume deprecation Factor11. The illumination scheme is designed in such a way that there should be fewer glares.12. The illumination scheme is designed in such a way that there should be minimum shadows.13. The control of light intensity is possible.14. Assume the illumination efficiency of those specific lamps which are to be used.15. Provide safety and prevent accident.



16. Take care to achieve desired energy saving.
17. Choose lamp with higher luminous efficiency, better color, and longer life
18. For any type of illumination scheme the maintenance & repairing should be less.
19. The cost of the designed illumination scheme should be low

d) Explain the principle of power factors improvement.

Ans:

Principle of power factors improvement:-

(4 Marks)

We know that,

$$P = \sqrt{3} V_L I_L \cos\phi$$

- For same power to be transmitted
- At same voltage
- Over a same distance

$$I \propto \frac{1}{\cos\phi} \propto \frac{1}{P.f}$$

- From above equation it is seen that as power factor increases current decreases, due to decreases in current, system has advantages.

➤ **OR**

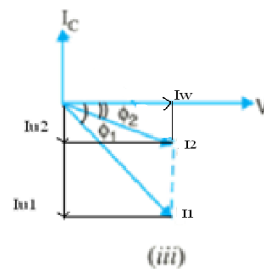
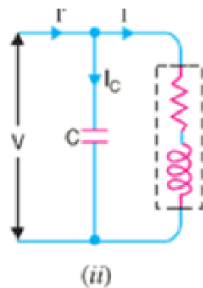

OR

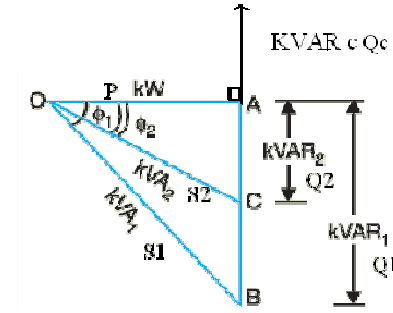

Q.1B) Attempt any ONE : **(1x6=6)**

a) i) (i) Define electrical braking.

Ans: Electrical braking: **(1 Marks)**

It is necessary to stop the vehicle when mechanical working is over or when required within reasonable time by use of electrical energy.

a) ii) State its types electrical braking

Ans: Types of Electrical Braking: (Any two types expected---- 1 Mark)

Electrical braking system:

1. Plugging
2. Rheostatic (Dynamic) Braking
3. Regenerative Braking
4. Electromagnetic Braking
5. Eddy current braking

a) iii) Explain regenerative braking for D.C. series motor.

Ans: **(Fig.—2 Marks, Explanation --- 2 Marks)**

Schematic diagram of regenerative braking of D.C. series :-

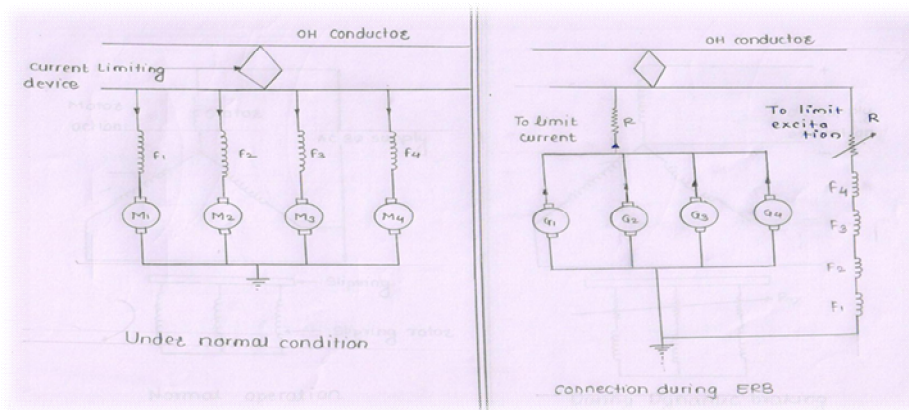

Fig. --- A

Fig. --- B



Explanation of regenerative braking:

- During normal running, motors are connected in parallel with field winding in series w.r.t. armature as shown in figure A.
- At the time of regenerating braking all the armature are connected in parallel without series field winding and all series field winding are connected in series with external resistance & are separately excited as shown in fig.B
- At this time motor acts as a generator and excitation current is so adjusted that generated voltage (E_g) is greater than supply voltage (V), so that power will be fed back to supply.
- This process is continued up to the speed of train reaches up to 20 to 16 km/hr. after that it is difficult to maintain generated voltage greater than supply voltage. So, electric regenerative braking is stopped
- For final stop mechanical braking is applied.
- External Resistances are connected to limit the current.

b) Explain with the diagram butt welding. State its applications.

Ans: **(Diagram----- 2 Marks, Explanation----- 2 Marks, Applications----- 2 Marks, Total 6 Marks)**

Diagram butt welding:-

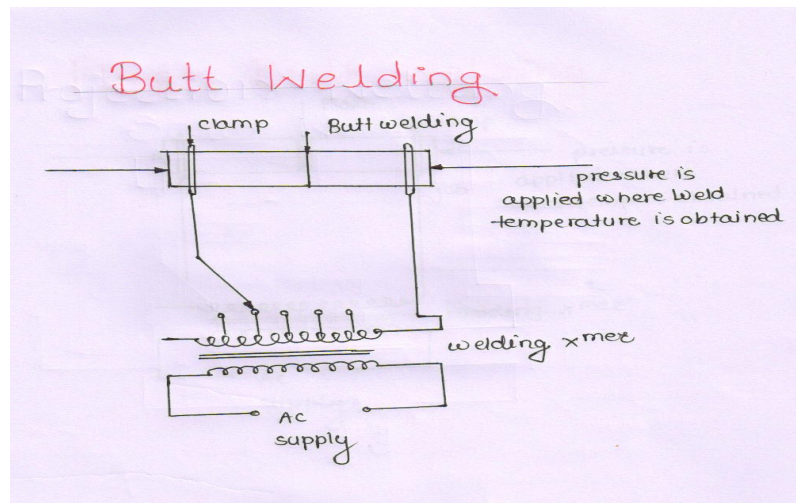



	<p>Explanation:</p> <ul style="list-style-type: none">➤ Transformer used for welding is designed for low voltage and high current secondary.➤ Transformer is oil cooled➤ The job is clamped as shown in fig. two parts which are to be welded are brought together➤ Sufficiently heavy current is passed through joints by welding transformer,➤ which creates necessary heat at joints due to I^2R➤ When welding temperature is reached supply is cut down.➤ And external pressure is applied simultaneously across the job to complete weld <p>Application Butt Welding:</p> <ol style="list-style-type: none">1) For welding rod, wire, pipe etc2) For joining thick metal plates or bars at end
Q.2	Attempt any FOUR : (4x4=16 Mark)
a)	State four advantages of electrical braking over mechanical braking.
Ans:	<p style="text-align: center;">(Any Four Advantages expected : 1 Mark each, Total 4 Marks)</p> <p>Following are the advantages of electrical braking over mechanical braking system.</p> <p><u>Advantages:</u></p> <ol style="list-style-type: none">1. It is most reliable braking system.2. Braking actuation time is small as higher value of braking retardation is obtained.3. Electrical braking is smooth & gradual.4. Life of braking system is more.5. There is less wear & tear of brake shoes, break block etc. so there is less maintenance cost.6. Higher speeds are possible even when train is going down the gradient, as braking system is reliable.7. Trains having heavy loads can be stopped even when train going up the gradient.8. Higher speeds of train is possible as braking system is reliable so pay load capacity increases.9. In case of electric regenerative braking we can utilize 60 to 80% of kinetic energy to generate electricity which is not possible with mechanical braking.



b)	State desirable properties of heating elements used in indirect resistance heating.										
Ans:	<p style="text-align: center;">(Any Four properties are expected : 1 Mark each, Total 4 Marks)</p> <p style="text-align: center;">Following properties of good heating material in indirect resistance heating:-</p> <ol style="list-style-type: none"> 1. High resistivity: It should have high resistivity. So that it becomes compact in size and produces more heat with small input current. 2. High melting point: It should have high melting point to withstand at high temperature. 3. High Oxidizing temperature: It should have high oxidizing temperature or it should not oxidize even at high temperature. 4. High Resistance to corrosion: It should have high resistance to corrosion to avoid rusting. 5. High Mechanical Strength: It should have high mechanical strength to withstand from mechanical injury. 6. Ductile: It should be ductile so that it can be manufactured into different size & shape. 7. Long Life: It should have long life. 8. Less Costly: It should be less costly and easily available. 9. Low temperature co-efficient of resistance: For accurate temperature control, it should have low temperature co-efficient of resistance. 10. It should not be brittle. 										
c)	Compare A.C. and D.C. system of traction (any four points).										
Ans:	<p style="text-align: center;">Compare A.C. and D.C. system of traction:</p> <p style="text-align: center;">(Any Four point expected: 1 Mark each, Total 4 Marks)</p> <table border="1" style="width: 100%; border-collapse: collapse; margin-top: 10px;"> <thead> <tr> <th style="width: 10%;">S.No</th> <th style="width: 30%;">Points</th> <th style="width: 30%;">AC System Traction</th> <th style="width: 30%;">DC System Traction</th> </tr> </thead> <tbody> <tr> <td style="text-align: center;">1</td> <td>Supply given to O/H condition</td> <td>1-ph, 25KV, AC 25 Hz</td> <td>600/750V-Tromways 1500/3000V urban/suburban</td> </tr> </tbody> </table>			S.No	Points	AC System Traction	DC System Traction	1	Supply given to O/H condition	1-ph, 25KV, AC 25 Hz	600/750V-Tromways 1500/3000V urban/suburban
S.No	Points	AC System Traction	DC System Traction								
1	Supply given to O/H condition	1-ph, 25KV, AC 25 Hz	600/750V-Tromways 1500/3000V urban/suburban								



MAHARASHTRA STATE BOARD OF TECHNICAL EDUCATION
(Autonomous)
(ISO/IEC-27001-2005 Certified)

Summer– 2017 Examinations

Subject Code: 17507

Model Answer

Page 9 of 33

2	Type of drive used	1-ph, AC series motor	DC series motor for tramways. DC compound motor
3	Weight of traction motor	1.5 times more than d.c. series motor.	1.5 times less than a.c series motor
4	Starting torque	Less starting torque	High starting torque
5	Accel ⁿ and retardation	Less than d.c series motor	High
6	Overload capacity	Less than d.c series motor	High
7	Method of speed control	Simple and smooth	Limited, except chopper method
8	Maintenance cost of traction motor	More	Less
9	Starting Efficiency	More	Less
10	Regenerative braking	Easy	Difficult
11	Ridding quality	Less, better than d.c.	Smooth (Better)
12	Insulation cost	High	Low
13	Cross section of conductor	Less	More
14	Design of supporting structure	light	Heavy
15	Distance between two substation	More	Less
16	No. of substation required for same track distance.	Less	More
17	Size (capacity) of traction substation	More	Less
18	Capital & maintenance cost of substation	Less	More
19	Cost track electrification for same track distance	Less	More
20	Electrolysis trouble	No	Yes, if ground is used as return path
21	Applications	Main line services	Urban and suburban area

d) Explain the suitability of 3-phase induction motor for traction service.

Ans: **(Any Four points expected: 1 Mark each, Total 4 Marks)**

Suitability of 3-phase induction motor for traction service because of following points:-

1. It is robust in construction and capable to withstand against continuous vibration.



	<ol style="list-style-type: none">2. Simple in design & construction.3. Slip-ring induction has high starting torque when external resistance is added in rotor circuit.4. Since the torque speed characteristic of the induction motor is markedly steeper, the induction machine can take better advantage of maximum possible tractive effort.5. No restriction on speed of motor because of absence of commutators.6. Speed control methods are simple7. Power to weight ratio of induction motor is much higher than the DC motor.8. High efficiency.9. Require little maintenance. Apart from bearing, it has no parts subjected to wear. It is not much effected by dust, vibration and heat10. Less maintenance.11. A high mean adhesion coefficient can be expected.12. The induction motor drives are about 20% energy efficient compared to DC drives.13. Three phase drives allow regeneration and unity power factor operation.14. The energy saving due to regeneration and improved power factor are sizable.15. It operates at high voltage (3.3 / 3.7 KV) consequently requiring less amount of current16. Automatic regeneration is the main advantage of I.M.17. Trouble free operation.
e)	Draw single line diagram of 132 kV/25 kV traction substation.
Ans:	Single line diagram of 132 kV/25 kV traction substation:

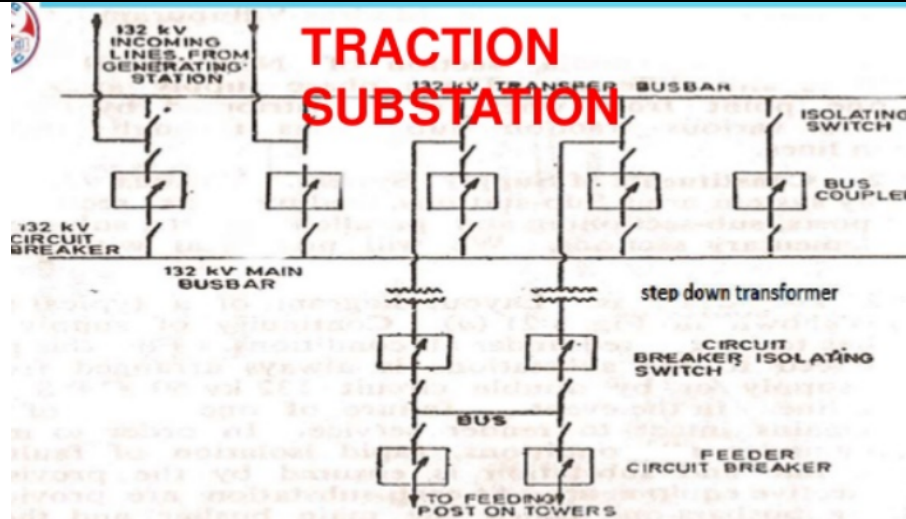

Q.3	Attempt any TWO : (2 x 8 =16 Marks)
a)	Explain the requirements of elevator motor. State with reason best suitable motor for elevator.
Ans:	Ideal requirements of elevator motor: (Any Six requirements are Expected: 6 Marks, suitable motor for elevator – 2 Marks, Total 8 Marks.) <ol style="list-style-type: none">1. High starting torque along with high rate of acceleration and retardation.2. Motors are compact in size especially smaller in diameter.3. Speed of motor should not exceed 900 rpm4. It should have sufficient overload capacity.5. Low initial and maintenance cost.6. Long life.7. It should withstand for rapid fluctuation in supply voltage Following motors are used because it covers all above requirements:- <ol style="list-style-type: none">1. DC Series Motor2. Ac Series Motor (1-ph)3. 3-Ph Slip ring I.M4. Permanent magnet AC Motor.5. Split Phase AC I.M.6. Capacitor Start I.M.
b)	Explain with neat diagram construction and working of Ajax Wyatt vertical core induction furnace.
Ans:	(Diagram---3 Marks, Construction---- 2 Marks, Working----- 3Marks, Total 8 Marks)



Neat sketch of 'Ajax Wyatt' vertical core furnace:

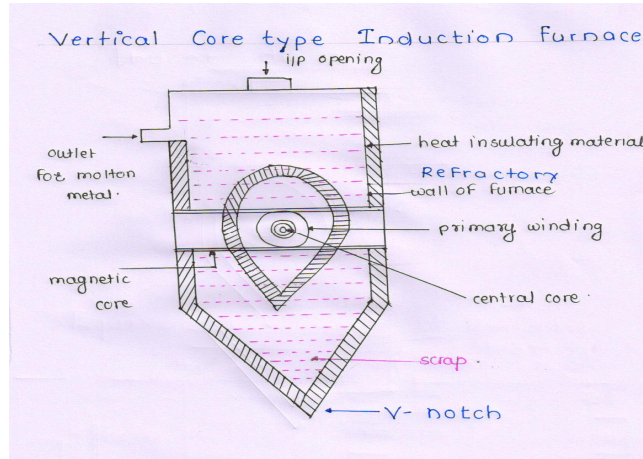

Construction of 'Ajax Wyatt' vertical core furnace:

Vertical core type induction heating furnace is nothing but transformer. It consists of following main parts:-

➤ Magnetic Core:

Primary winding

Secondary Winding:

- Refractory Wall
- Opening
- Cooling arrangement
- Tilting arrangement
- Control panel
- APFC

Working:

It is based on principle of transformer. In this type of Induction heating primary winding is as usual which is wound around one limb of magnetic core but secondary winding is actually charge which is to be melted is kept in crucible.

When AC Supply is given to primary winding current flows through primary winding which creates alternating flux in magnetic core this flux links to the secondary winding i.e. charge through magnetic core. Hence according to faraday's law of electromagnetic induction



	\therefore rating of motor (kw) \cong 10 kW -----(2Mark)
Q.4A)	Attempt any THREE : (3 x 4 =12 Marks)
a)	State four advantages of seam welding over spot welding.
Ans:	(Four advantages are expected 1 Mark each, Total 4 Mark) Advantages of seam welding over spot welding:- 1. Due to seam welding we get continuous weld which is air-tight 2. Gas tight as well as liquid tight joints can be made. 3. The Overlap is less than spot or projection welding. 4. The production of single seam weld and parallel seams can be got simultaneously. 5. Efficient energy use.
b)	Define the following : (i) Luminous intensity (ii) Utilization factor (iii) Depreciation factor (iv) Mean spherical candle power (Each definition : 1 Mark , Total 4 Mark)
Ans:	1) Luminous intensity:- The luminous intensity in any particular direction is the luminous flux emitted by source per unit solid angle is called the luminous intensity of the source. And its unit is Candela OR $I = \frac{\phi}{w}$ (Where ϕ = luminous flux, w = Solid Angle) ii) Utilization factor: It is defined as the ratio of total lumens reaching the working plane to the total lumens given out by the lamp. Its value is always less than one. (iii) Depreciation factor It is defined as the ratio of initial illumination to the ultimate maintained illumination on the working plane. OR $\text{Depreciation factor} = \frac{1}{\text{Maintenance Factor}}$ iv) MSCP (Mean Spherical Candle power): It is the average of all candle powers in all direction in all planes. OR $\text{MSCP} = \frac{\text{Total Luminous lux in lumens}}{4\pi}$



c)	State and explain four types of tariff applicable to H.T. and industrial consumers.
Ans:	<p style="text-align: center;">(Names of tariffs --- 1Mark, Explanation---3Marks, Total 4 Marks)</p> <p>Following tariffs are applicable to industrial/ HT consumers:-</p> <p>Types of Tariff:-</p> <ol style="list-style-type: none">1. Maximum demand Tariff (KVA maximum demand Tariff)2. Power factor Tariff3. TOD (Time of Day) Tariff4. KW and KVAR Tariff <p>1. <u>Maximum Demand Tariff/KVA Maximum Demand Tariff / Load factor tariff:-</u></p> <ul style="list-style-type: none">➤ It is similar to two part tariff except that maximum demand (KVA) is actually measured by <u>installing maximum demand meter</u> (in KVA)➤ M.D. Meter (it is an electromagnetic or electronic trivector meter) is installed in the premises of consumer, in addition to energy meter. <div style="border: 1px solid black; padding: 5px; margin: 10px 0;"><p>Maximum Demand Tariff / Load factor Tariff = $M.D. (KVA) \times Rs 'X' \text{ permonth} + \{Number of units (KWH) \text{ Actual consumer}\} \times Rs 'Y'$</p></div> <p>2. <u>Power Factor Tariff (Sliding Scale Tariff or Average P.F. Tariff):-</u></p> <p><u>In addition to basic tariff the tariff in which P.F. of industrial consumer is taken into consideration for billing.</u></p> <ul style="list-style-type: none">➤ If the P.F. of consumer is less than P.F. declare by Supply Company (say below 0.9 Lag.) than penalty will be charged in energy bill.➤ If The P.F. of consumer is more than P.F. declare by Supply Company (say above 0.95lag.) than discount will be given in energy bill.➤ As usual consumer has to pay actual energy consumption charges <p>3. <u>Time of Day (TOD) Tariff or OFF-load Tariff:-</u></p>



MAHARASHTRA STATE BOARD OF TECHNICAL EDUCATION
(Autonomous)
(ISO/IEC-27001-2005 Certified)

Summer– 2017 Examinations

Subject Code: 17507

Model Answer

Page 17 of 33

	= 1.988 KVAR -----	(1 Mark)																																																
Q. 4 B)	Attempt any ONE	06 Marks																																																
a)	Compare resistance welding and arc welding (any six points).																																																	
Ans:	(Any six points are expected, 1 Mark each point, Total 6 Marks.)																																																	
	<table border="1" style="width: 100%; border-collapse: collapse;"> <thead> <tr> <th style="width: 10%;">Sr.No</th> <th style="width: 25%;">Parameters</th> <th style="width: 30%;">Resistance Welding</th> <th style="width: 35%;">Arc Welding</th> </tr> </thead> <tbody> <tr> <td>1</td> <td>Type of welding</td> <td>Plastic / Pressure / Non-fusion welding</td> <td>Fusion / Non pressure welding</td> </tr> <tr> <td>2</td> <td>Principle of heat developed</td> <td>Heat is developed due to I^2R losses where R is the contact resistance</td> <td>Heat developed due to arc produced in between electrode and job</td> </tr> <tr> <td>3</td> <td>External filler material required</td> <td>Not required during welding</td> <td>Required during welding</td> </tr> <tr> <td>4</td> <td>External pressure required</td> <td>Required</td> <td>Not required</td> </tr> <tr> <td>5</td> <td>Type of supply used</td> <td>Both AC, DC supply is used. But generally Ac Supply is used.</td> <td><u>Metal arc welding</u> – Both AC, DC supply is used. But generally Ac Supply is used. and for <u>Carbon arc welding</u> –only DC supply are used</td> </tr> <tr> <td>6</td> <td>Voltage & current required</td> <td>Low voltage (2 to 20V AC) and high current (40 to 400A, in some cases 5 to 20KA) supply is required</td> <td><u>Metal Arc welding Voltage</u>- 70 to 100V AC and <u>Carbon arc welding voltage</u>- 50 to 60V DC, Current- 50-600-800A</td> </tr> <tr> <td>7</td> <td>Energy consumption</td> <td>Low (3 to 4 KWH/Kg of deposited material)</td> <td>High (5 to 10 KWH/Kg of deposited material.)</td> </tr> <tr> <td>8</td> <td>Temperature obtained</td> <td>Temperature obtained is not very high (up to 1350⁰C)</td> <td>Temperature obtained is very high (up to 3500⁰C to 6000⁰C)</td> </tr> <tr> <td>9</td> <td>Power factor</td> <td>Low</td> <td>Poor</td> </tr> <tr> <td>10</td> <td>Type of electrode</td> <td>Non-consumable electrodes are used.</td> <td>Coated electrodes are used for metal arc welding and bare electrodes are used for carbon arc welding. (Electrodes may be consumable or non-consumable)</td> </tr> <tr> <td>1.</td> <td>Application</td> <td>It is suitable for mass production</td> <td>It is suitable for heavy job, maintenance and repair work</td> </tr> </tbody> </table>	Sr.No	Parameters	Resistance Welding	Arc Welding	1	Type of welding	Plastic / Pressure / Non-fusion welding	Fusion / Non pressure welding	2	Principle of heat developed	Heat is developed due to I^2R losses where R is the contact resistance	Heat developed due to arc produced in between electrode and job	3	External filler material required	Not required during welding	Required during welding	4	External pressure required	Required	Not required	5	Type of supply used	Both AC, DC supply is used. But generally Ac Supply is used.	<u>Metal arc welding</u> – Both AC, DC supply is used. But generally Ac Supply is used. and for <u>Carbon arc welding</u> –only DC supply are used	6	Voltage & current required	Low voltage (2 to 20V AC) and high current (40 to 400A, in some cases 5 to 20KA) supply is required	<u>Metal Arc welding Voltage</u> - 70 to 100V AC and <u>Carbon arc welding voltage</u> - 50 to 60V DC, Current- 50-600-800A	7	Energy consumption	Low (3 to 4 KWH/Kg of deposited material)	High (5 to 10 KWH/Kg of deposited material.)	8	Temperature obtained	Temperature obtained is not very high (up to 1350 ⁰ C)	Temperature obtained is very high (up to 3500 ⁰ C to 6000 ⁰ C)	9	Power factor	Low	Poor	10	Type of electrode	Non-consumable electrodes are used.	Coated electrodes are used for metal arc welding and bare electrodes are used for carbon arc welding. (Electrodes may be consumable or non-consumable)	1.	Application	It is suitable for mass production	It is suitable for heavy job, maintenance and repair work	
Sr.No	Parameters	Resistance Welding	Arc Welding																																															
1	Type of welding	Plastic / Pressure / Non-fusion welding	Fusion / Non pressure welding																																															
2	Principle of heat developed	Heat is developed due to I^2R losses where R is the contact resistance	Heat developed due to arc produced in between electrode and job																																															
3	External filler material required	Not required during welding	Required during welding																																															
4	External pressure required	Required	Not required																																															
5	Type of supply used	Both AC, DC supply is used. But generally Ac Supply is used.	<u>Metal arc welding</u> – Both AC, DC supply is used. But generally Ac Supply is used. and for <u>Carbon arc welding</u> –only DC supply are used																																															
6	Voltage & current required	Low voltage (2 to 20V AC) and high current (40 to 400A, in some cases 5 to 20KA) supply is required	<u>Metal Arc welding Voltage</u> - 70 to 100V AC and <u>Carbon arc welding voltage</u> - 50 to 60V DC, Current- 50-600-800A																																															
7	Energy consumption	Low (3 to 4 KWH/Kg of deposited material)	High (5 to 10 KWH/Kg of deposited material.)																																															
8	Temperature obtained	Temperature obtained is not very high (up to 1350 ⁰ C)	Temperature obtained is very high (up to 3500 ⁰ C to 6000 ⁰ C)																																															
9	Power factor	Low	Poor																																															
10	Type of electrode	Non-consumable electrodes are used.	Coated electrodes are used for metal arc welding and bare electrodes are used for carbon arc welding. (Electrodes may be consumable or non-consumable)																																															
1.	Application	It is suitable for mass production	It is suitable for heavy job, maintenance and repair work																																															
b)	Explain the factors affecting framing of tariffs.																																																	
Ans:	1 x 6 = 6 (Six factors are expected, 1 Mark each, Total 6 Marks)																																																	



	<p>Factors affecting framing of tariffs:-</p> <ol style="list-style-type: none">1. Total recovery of all taxes , duties and other charges2. Expenses on premium (installment) paid to insurance company.3. T&D losses.4. Electricity cannot be stored economically. It has to be consumed as soon as it is generated.5. Additional supply charges (ADC) to compensate the costly purchase energy (power) from outside to reduce the load shading.6. Investment required for future expansion.7. Economics as compare to other types of energy sources.i.e.to encourage the consumers to use electricity.8. Applying different tariff for different types of consumers.i.e. Proper return is secured from each consumer.9. Applying tariff high during peak load period.10. Applying tariff low during off load period.11. For industrial consumer, in addition to basic tariff incentives and penalty related to P.F and L.F.12. The tariff should be simple cheap and capable of easy explanation to consumers.
Q.5	Attempt any FOUR : (4 x4=16 Marks)
a)	State the following : (i) Law of inverse squares (ii) Lambert's Cosine law
Ans:	<p>(Each law—2Marks, Total-4 Marks)</p> <p>Inverse Square Law:-</p> <p>Intensity of illumination produced by a point source varies inversely as square of the distance from source.</p>

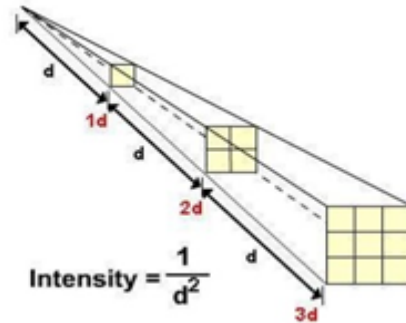

$$E = \frac{I}{d^2}$$

Where,

I = intensity and d = Distance

Distance from Source

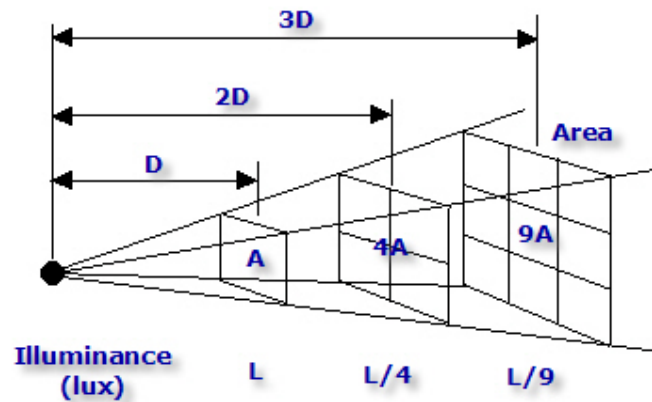

(ii) Lambert's Cosine law:

According to this law, Illumination at any point on a surface is proportional to the cosine of the angle between the normal at that point and the direction of luminous flux.

Cosine Law: $E_{\theta} = E \cdot \cos(\theta)$

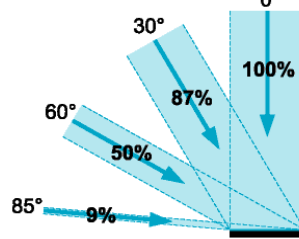

Fig. 6.3 Lambert's cosine law.

OR

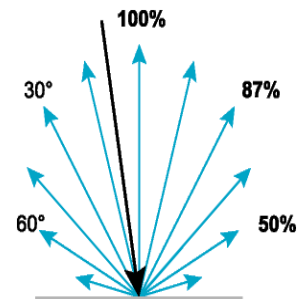
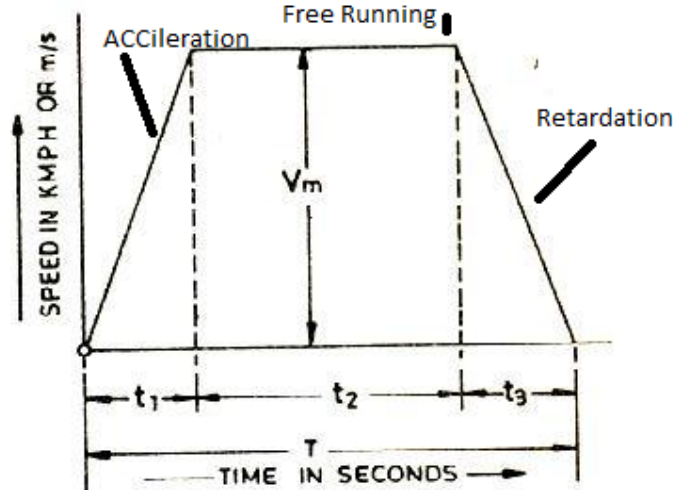

Fig. 6.5 Lambertian surface.



<p>b)</p> <p>Ans:</p>	<p>Justify the use of saturable reactor to control the magnitude of welding current. (4 Marks)</p> <p>A saturable reactor in electrical engineering is a special form of inductor where the magnetic core can be deliberately saturated by a direct electric current in a control winding. Once saturated, the inductance of the saturable reactor drops dramatically. This decreases inductive reactance and allows increased flow of the AC current.</p> <p>Saturable reactors often have multiple taps, allowing a small inductance to be used with a large load or a larger inductance to be used with a smaller load. In this way, the required magnitude of the control current can be also held roughly constant, no matter what the load.</p>
<p>c)</p> <p>Ans:</p>	<p>Draw labelled speed-time curve for main line. Explain various parts of the curve.</p> <p>Typical speed time curve for main traction line :</p> <p style="text-align: right;">(Curve 2 Marks, Explanation 2 Marks, Total, 4 Mark)</p> <p style="text-align: center;">OR</p>



Speed Time Curve Explanation:-

There are five periods in the run of train as shown in speed time curve.

i) Constant acceleration period (o to A):-

During this period starting resistance in motor circuit are gradually cut down. At point 'A' all the starting resistance in motor circuit has been cut down.

ii) Acceleration on speed –Time curve (A to B) For T_2 sec.:-

Now train is continuous to accelerate & torque gradually falls until speed of train exactly balance train resistance during this period.

iii) Free Running or constant period (B to C) For T_3 sec.:-

At the end of acceleration period train attend maximum speed. During this free tuning period train runs at constant speed & constant power is taken from supply by train.

iv) Coasting period (C to D) For T_4 sec.:-

At the end of free running period the supply to traction motor is cut down & train allow to run under its own movement. The speed of train goes on decreasing due to resistance to motion of train. Rate of decreasing of speed during costing period is known as costing retardation (β_c)

v) Braking period (D to E) For T_5 sec.:-

At the end of costing period brakes are applied to bring the train to rest (stop) during this period speed of train rapidly decreases & reduces to zero. The rate of decreases of speed



	during braking period is known as ‘Braking retardation’ (β)													
d)	Explain which system is preferred for traction work in India.													
Ans:	<p style="text-align: center;"><u>Single phase, 25 KV AC system is preferred for traction work in India</u> (2 Marks)</p> <p style="text-align: center;">It is explained on following point:- (Any two Points are Expected)</p> <p>1) Supply fed to traction sub-station:- (2 Marks)</p> <p style="padding-left: 40px;">Traction sub-station receives AC power from a 3-ph high voltage nearest transmission line. For e.g. – 220/ 132 / 110 KV etc.</p> <p>2) Equipment in sub-station:-</p> <p style="padding-left: 40px;">In traction sub-station input voltage is step down to utilization voltage (1-ph, 25KV, AC) So main equipments in traction substation are</p> <table style="margin-left: 80px; width: 80%;"> <tr> <td style="width: 50%;">a. Step down transformer</td> <td style="width: 50%;">b. Protective equipments,</td> </tr> <tr> <td>c. Switchgear</td> <td>d. Control panel etc.</td> </tr> </table> <p>3) Number of Overhead conductor:-</p> <p style="padding-left: 40px;">Single conductor contact wire is used and return being through rail.</p> <p>4) Normal Voltage fed to overhead conductor:</p> <p style="padding-left: 40px;">Voltage: - 1-ph, 25 KV A.C. Frequency: - Standard ,50 Hz</p> <p>5) Equipment in motor coach (locomotive):-</p> <p style="padding-left: 40px;">As working voltage of 1-ph AC series motor is 300/400 V AC. So supply voltage must be step down in locomotive with the help of step down transformer. This is installed in motor coach.</p> <p>6) Types of drives used:-</p> <p style="padding-left: 40px;">To obtain mechanical power to move the train 1-ph AC series motor is used. The working voltage of motor is 1-ph AC, 300/400V.</p> <p>7) Advantages:- (Any two advantages are expected)</p> <ol style="list-style-type: none"> 1. As system voltage is high (25KV) as compared to DC supply system (1500 /3000V) so current drawn by overhead conductor is less because. (since $I \propto 1/V$) 2. Due to low current cross section of overhead conductor reduces. So its weight reduces. <table border="1" style="margin-left: auto; margin-right: auto; border-collapse: collapse; text-align: center;"> <thead> <tr> <th style="width: 10%;">Sr.No.</th> <th style="width: 40%;">Supply System</th> <th style="width: 50%;">Weight of copper conductor</th> </tr> </thead> <tbody> <tr> <td>1</td> <td>AC System</td> <td>2.57 T / Km</td> </tr> <tr> <td>2</td> <td>DC System</td> <td>5.265 T / Km</td> </tr> </tbody> </table>	a. Step down transformer	b. Protective equipments,	c. Switchgear	d. Control panel etc.	Sr.No.	Supply System	Weight of copper conductor	1	AC System	2.57 T / Km	2	DC System	5.265 T / Km
a. Step down transformer	b. Protective equipments,													
c. Switchgear	d. Control panel etc.													
Sr.No.	Supply System	Weight of copper conductor												
1	AC System	2.57 T / Km												
2	DC System	5.265 T / Km												



3. As weight of overhead conductor reduces design of supporting structure becomes lighter.
4. Due to low current copper losses in transmission line reduces, so transmission efficiency increases.
5. Due to low current voltage drop in transmission line decreases. Due to this distance between two substation increases. So number of substation required is less than DC track electrification system for same track distance. e.g.

S.No.	Voltage level	Distance between 2 substation
1	1-ph AC, 25KV	50 to 80 KM
2	3000V DC	12 to 30 KM
3	1500V DC	5 to 12 KM
4	750/600V DC	3 to 5 KM

6. Due to low current size (capacity) of AC substation is more than DC substation. So number of substation required is less than DC track electrification system for same track distance.

Sr.No.	Supply System	Size of Substation
1	1-ph AC, 25KV	10 to 15 MW
2	3000V DC	2 to 6 MW

7. Due to all above advantages cost of track electrification less as compared to DC track electrification system.
8. Since here 1-Ph AC series motor is used to obtain mechanical power and its Characteristics such as high starting torque, variable speed are suitable for traction purpose.
9. Starting efficiency is high in case of AC supply system as voltage is reduced with the help of transformer.

e) Explain with neat sketches series parallel control of traction motors.

Ans:

(Series steps---- 2Marks, Parallel steps----- 2Marks, Total 4 Marks)

Series parallel control of DC series motor

1. For traction purpose, two motors are operated in following steps.

Series steps of traction motor:

Step 1 –

- Two traction motors M1 and M2 are connected in series and started with all starting resistances in series.

Step 2 to 7 –

- The starting resistances are cut out one by one gradually and finally two motors are in series



without any resistance.

- In series connection the supply voltage V is divided in two motors. (Both motors get half or $(V/2)$ volts). So speed is also half. $(N/2)$

Series Steps

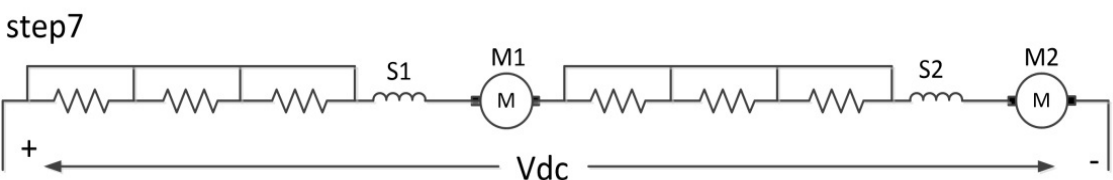
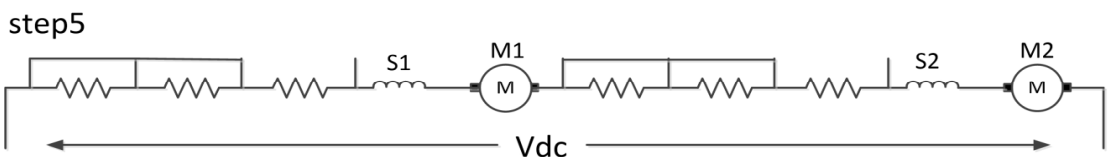
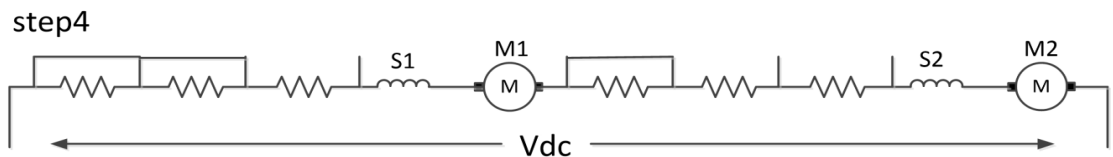
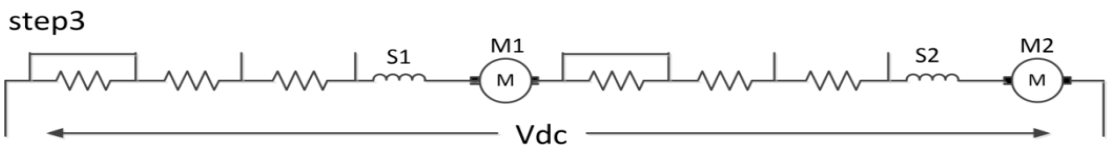
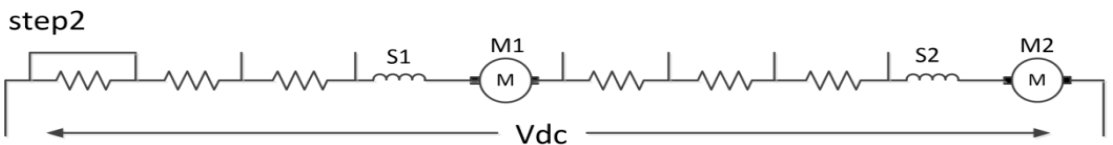
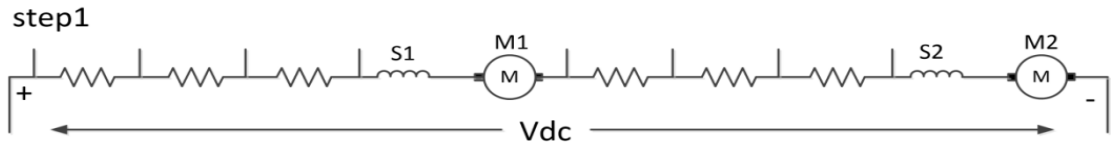

Voltage across each motor is $V_{dc}/2$ and speed is $N/2$ RPM



Parallel steps of traction motor:

Step 1 –

- After completion of series last step motors are now connected in parallel again with series resistance otherwise motor will draw very high current and may damage itself.

Step 4 to 7 –

- Both motors are now connected in complete parallel and starting resistances are cut out one by one.
- In parallel connection, voltage across M1 and M2 will be full i.e. V (voltage is always same in parallel).
- Voltage across each motor = V and speed of each motor = N
- So, voltage is now increased from $(V/2)$ to V .
- Hence, speed also increases from $(N/2)$ to N and motor runs with full speed.

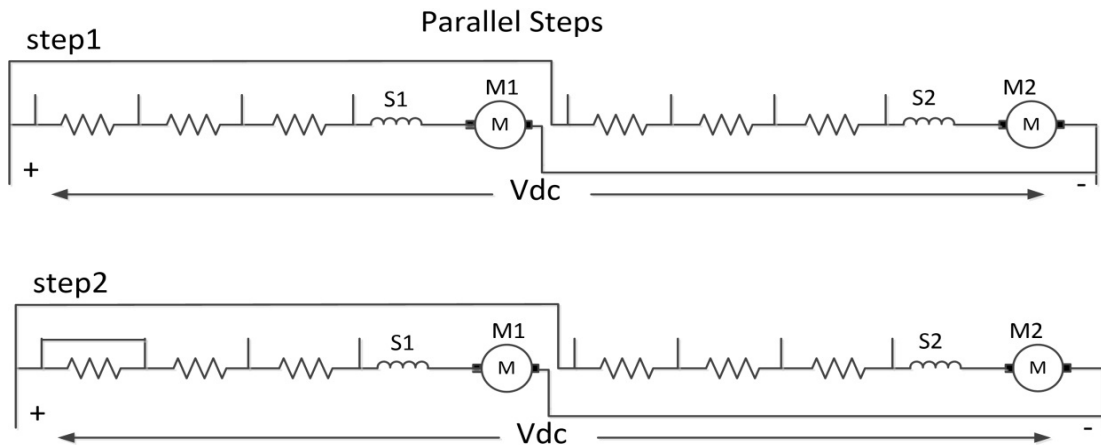

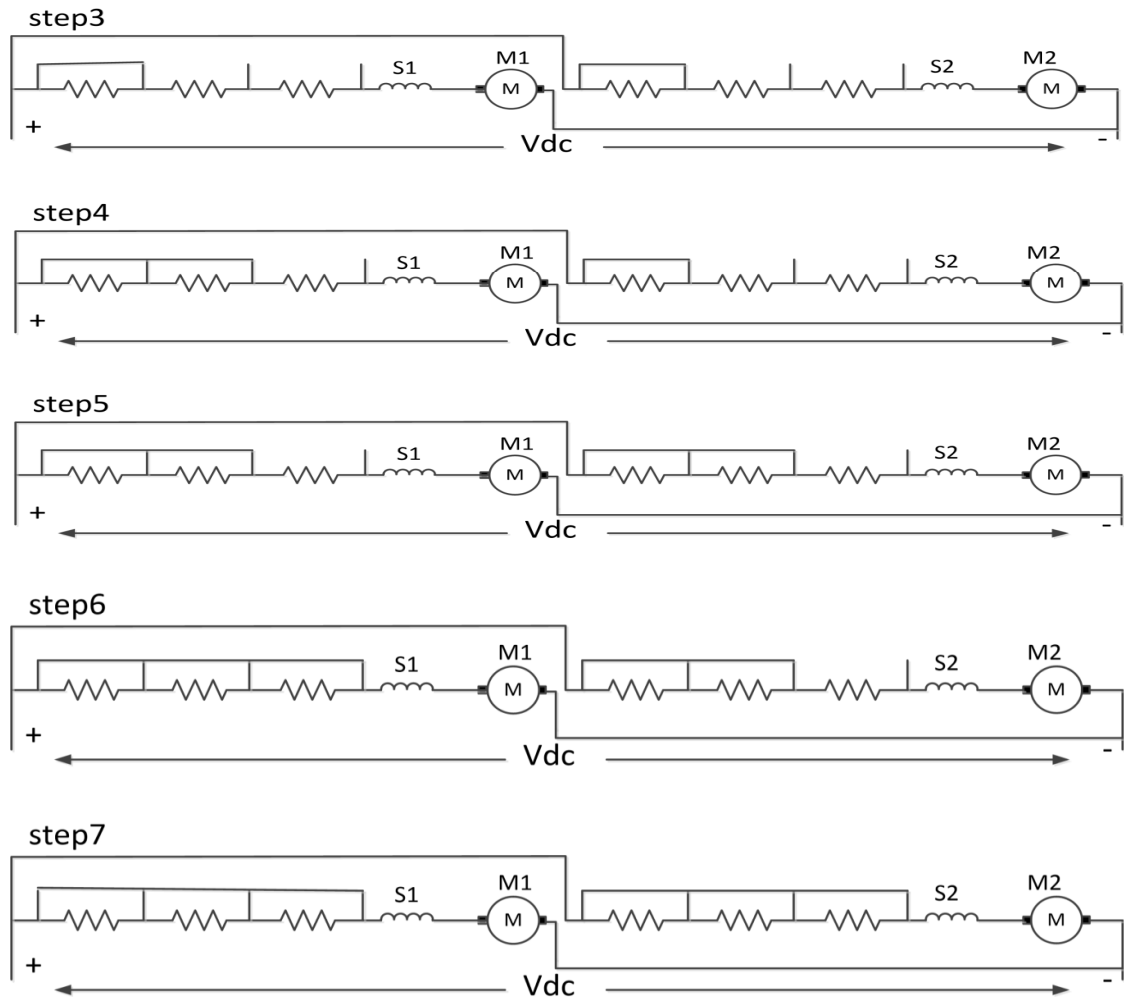

Voltage across each motor is V_{dc} and speed is N RPM

Advantages:

1. This method has highest starting efficiency than rheostat method.

Starting efficiency of plain rheostat method = 50 %. By this method for two motor it is 66.66% & for 4 motors it is 72.72% and for 6 motors it is 75%

2. Different economical speeds are obtained:

- For 2 Motor = 1 :2
- For 4 Motor = 1:2:4
- For 6 Motor = 1:2:3



3) For same power input torque of different magnitude is obtained.

Disadvantages:

1. If proper transition method is not used then

- There is loss of torque when motors are disconnected from supply
- There will be jerk when motors are reconnected in parallel

Q.6 Attempt any TWO of the following : 16 Marks

a) i) (i) Differentiate between core type and core less induction furnace.

Ans:

(Any Four Points are expected 1 Mark each, Total 4 Marks)

Sr.No.	Core type induction furnace.	Core less induction furnace.
1.	Less leakage flux	More leakage flux
2.	Power factor is good	Power factor is poor
3.	Works at normal frequency	High frequency supply is required
4.	Weight & size is more	As there is no magnetic core weight & size of furnace reduces.
5.	Design for high capacity	Design for low capacity
6.	Crucible used is either Horizontal or Vertical	Crucible of any shape is used
7.	Initial cost is less	Initial cost is more as High frequency supply is required
8.	Used to melt only conducting metals	Both conducting and non-conducting charge can be heated.
9.	Time required for heating is more as normal frequency is used.	Due to high frequency, high voltage supply, time required for heating is less.

a) ii) Explain what is dielectric heating. State its four applications.

Ans:

(Explanation---2Marks, Applications—2 Marks, Total 4Marks)

Figure of dielectric heating:

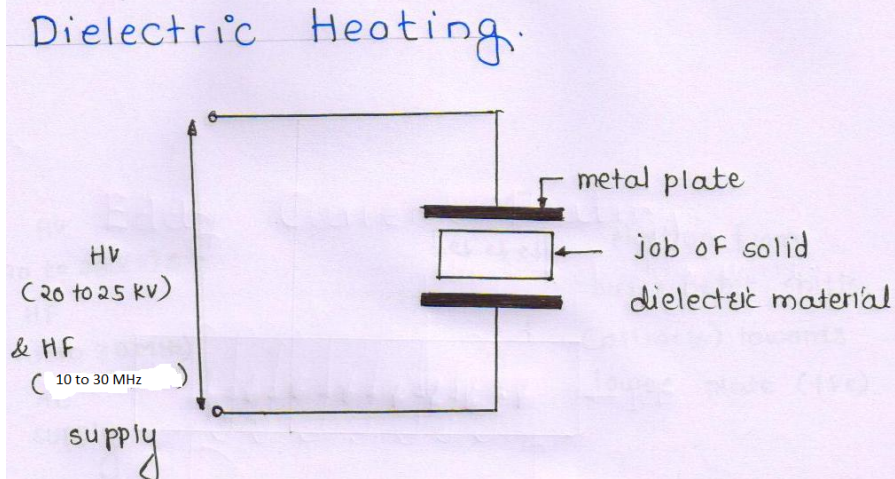

or equivalent figure

Principle of Dielectric heating:

For heating non-metallic material (dielectric material) for e.g. Glass, plastic, wood, etc. dielectric heating is used.

Material to be heated is placed between two metallic plates as shown in figure (1) across which a high voltage (20 to 25 KV) and high frequency (10 to 30 MHz) AC supply is given.

Material is heated due to dielectric loss taking place inside the job.

Operation :-

1. During (+)^{ve} half cycle:

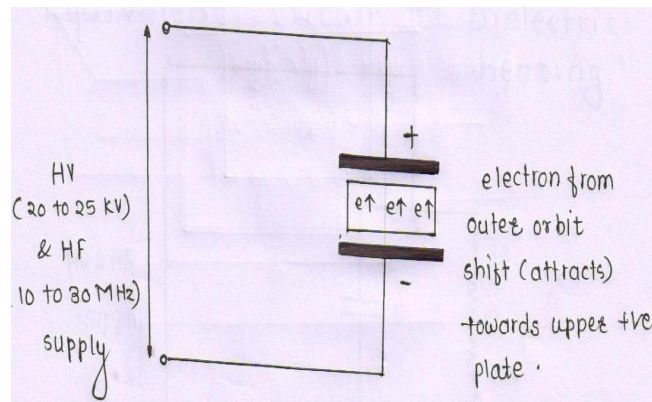

or equivalent figure

Material to be heated is placed between two metallic plates, if upper plate is + **Ve**, most of electrons from its outer orbit (of job) gets attracted towards + **Ve** plate.

2. During (-)^{ve} half cycle:

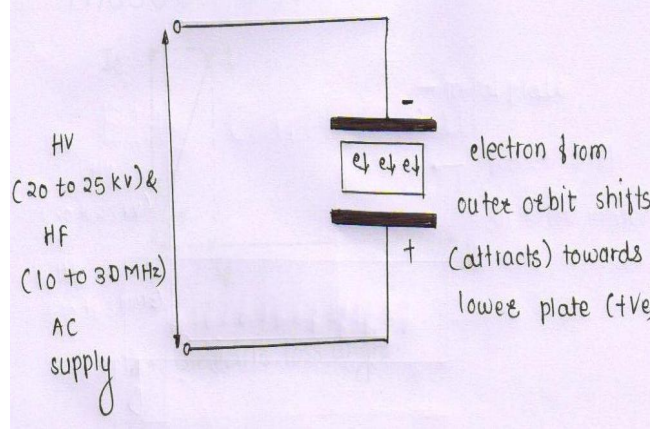

During - Ve half cycle field is reversed i.e. bottom plate becomes + Ve. At that time most of electrons from its outer orbit gets attracted towards bottom electrode.

Effect:-

Due to inter atomic friction caused by repeated (due to frequency) deformation and rotation of atomic structure, Dielectric loss takes place inside the job which produces heat.

Applications of Dielectric Heating:- (Any four application expected: 1/2 Mark each)

- 1) In food processing industry, dielectric heating is used for Baking of cakes & biscuits in bakeries.
- 2) Cooking of food without removing outer shell (e.g.-boiled egg) and pasteurizing of milk.
- 3) For Rubber vulcanizing.
- 4) In Tobacco manufacturing industry for dehydration of tobacco.
- 5) In wood industry for manufacturing of ply wood.
- 6) In plastic Industry for making different containers.
- 7) In cotton industry for drying & heating cotton cloths for different processes.
- 8) In tailoring industry for producing threads.
- 9) For manufacturing process of raincoats & umbrellas.
- 10) In medical lines for sterilization of instruments & bandages.
- 11) For heating of bones & tissues of body required for certain treatment to reduce pains & diseases.
- 12) For removal of moisture from oil.



	<p>13) For quick drying gum used for book binding purpose.</p> <p>14) In foundry for heating of sand, core, which are used in molding processes.</p>
b)	<p>An electric train has a schedule speed of 25 km/hr between stations 800 m apart. The duration of stop is 20 seconds, the maximum speed is 20% higher than average running speed and the braking retardation is 3 km/hr/sec. Determine rate of acceleration required to operate the train.</p>
Ans:	<p>Given:- Schedule speed of 25 km/hr, Distance between stations 800 m Stop time 20 Sec. Maximum speed is 20% higher than average running speed, Braking retardation is 3 km/hr/sec</p> <p style="margin-left: 40px;"> $\text{Scheduled speed} = \frac{3600D}{T_{sch}} \text{ ---- (1 Mark)}$ $T_{sch} = \frac{3600 \times 0.8}{25}$ $= 115.20 \text{ sec}$ $\text{Actual time of run} = T = T_{sch} - T_{stop}$ $= 115.20 - 20$ $= 95.20 \text{ sec.}$ <p style="text-align: right;">----- (1 Mark)</p> $\text{Average speed} = \frac{3600D}{T}$ $= \frac{3600 \times 0.8}{95.2}$ $= 30.2521 \text{ km/hr.}$ <p style="text-align: right;">----- (1 Mark)</p> $\text{Maximum Speed} = 1.2 \times \text{Average speed}$ $= 1.2 \times 30.2521$ $= 36.3025 \text{ km/hr.}$ <p style="text-align: right;">----- (1 Mark)</p> $\frac{1}{\alpha} + \frac{1}{\beta} = \frac{7200D}{V^2_{max}} = \left[\frac{V_{max}}{V_{ac}} - 1 \right]$ <p style="text-align: right;">----- (1 Mark)</p> $= \frac{7200D}{(36.3025)^2} = [1.2 - 1] = \frac{5760}{1317.87}$ <p style="text-align: right;">----- (1 Mark)</p> $\frac{1}{\alpha} + \frac{1}{\beta} = 0.8741$ </p>



$$\frac{1}{\alpha} = 0.8741 - \frac{1}{\beta}$$

----- (1 Mark)

$$= 0.8741 - \frac{1}{3}$$

$$\frac{1}{\alpha} = 0.5407$$
$$\alpha = 1.8495 \text{ kmphs}$$

----- (1 Mark)

c) i) **State any four advantages of high power factor.**

Ans: **Following Advantages of high power factor:**

(Any Four Advantages are expected: 1 Mark each, Total 4 Marks)

1. Cross section of conductor reduces:

$$\text{Cross section of conductor} \propto I \propto \frac{1}{\text{P. f}}$$

As P.F. increases current reduce so; cross section of conductor and its weight reduces hence its cost reduces

2. Design of supporting Structure:

As weight of conductor reduces design of supporting structure (tower) becomes lighter, so its cost reduces.

3. Cross section of terminal (contacts) reduces:

As power factor increases, current reduces. hence cross section of switchgear bus bar and contacts etc decreases.

4. Copper losses reduces:

As power factor increases current reduces. So copper losses reduces. As a effect efficiency increase.

5. Voltage drop reduces:

As P.F. increases, current decreases. So voltage drop decreases, So regulation gets improved (better)

6. Handling capacity (KW) of equipment increases:

As power factor increases, handling capacity of each equipment such as Alternator,



	<p>transformer increases</p> <p>7. KVA rating of equipments reduces:</p> <p>As P.F. increases, current decreases. So KVA rating of all equipments for eg- alternator, transformer etc decreases, so its capital cost reduces.</p> <p>8. Cost per unit (KWH) reduces:</p> <p>From all above advantages, it is seen that cost of generation, transmission & distribution decreases, so cost/unit reduces.</p> <p>Also performance i.e. efficiency & regulation gets improved at high power factor</p>
c) ii)	<p>A single phase 400 V, 50 Hz motor takes a supply current of 50 A at a P.F. of 0.6. The motor P.F. has to be improved to 0.9 by connecting a capacitor in parallel with it. Calculate the required capacity of capacitor in Farads</p>
Ans:	<p>Given Data : V = 400 V , f = 50 Hz , I = 50 amp. At 0.6 P.F. To be improve 0.9</p> $I_{\omega} = I_1 \times \cos\phi_1$ $I_{\omega} = 50 \times 0.6$ $I_{\omega} = 30 \text{ Amp} \text{ ----- (1 Mark)}$ $I_{\mu} = I_{\omega} \times \tan\phi_1$ $I_{\mu} = 30 \times 1.33$ $I_{\mu} = 39.9 \text{ Amp}$ $I_{\mu 2} = I_{\omega} \times \tan\phi_2$ $I_{\mu 2} = 30 \times 0.4843$ $I_{\mu 2} = 14.529 \text{ Amp}$ $I_C = I_{\mu 1} - I_{\mu 2}$ $I_C = 39.9 - 14.53$ $I_C = 25.37 \text{ Amp} \text{ ----- (1 Mark)}$



$$I_C = \frac{V}{X_C}$$

$$X_C = \frac{400}{25.37}$$

$$X_C = 15.76 \text{ Ohm}$$

----- (1 Mark)

$$C = \frac{1}{2 \pi F X_C}$$

$$C = \frac{1}{2 \pi \times 50 \times 15.76}$$

----- (1 Mark)

$$C = 2.019 \times 10^{-4} \text{ F}$$

-----END-----