



Important suggestions to examiners:

- 1) The answers should be examined by key words and not as word-to-word as given in the model answer scheme.
- 2) The model answer and the answer written by candidate may vary but the examiner may try to assess the understanding level of the candidate.
- 3) The language errors such as grammatical, spelling errors should not be given more importance. (Not applicable for subject English and communication skills)
- 4) While assessing figures, examiner may give credit for principle components indicated in a figure. The figures drawn by candidate and model answer may vary. The examiner may give credit for any equivalent figure drawn.
- 5) Credits may be given step wise for numerical problems. In some cases, the assumed constant values may vary and there may be some difference in the candidate's answers and model answer.
- 6) In case some questions credit may be given by judgment on part of examiner of relevant answer based on candidate understands.
- 7) For programming language papers, credit may be given to any other program based on equivalent concept.

Q.1 A)	Attempt any three :	12
a)	State any four factors to be considered while selecting electric drives (motor) for a particular application.	
Ans:	(Any Four Points From The Following Or Equivalent Points Are Expected 1 Mark To Each Point, Total 4 Marks) Following Factors governing / or are considered while selecting electric drive (Motor) for particular application: 1. Nature of supply: Whether supply available is <ul style="list-style-type: none">➤ AC,➤ Pure DC➤ Or Rectified DC 2. Nature of Drive (Motor): Whether motor is used to drive (run) <ul style="list-style-type: none">➤ Individual machine➤ OR group of machines. 3. Nature of load: Whether load required light or heavy starting torque <ul style="list-style-type: none">➤ OR load having high inertia, require high starting torque for long duration.➤ OR Whether load torque increases with speed ($T \propto N$)	



	<ul style="list-style-type: none">➤ OR decreases with speed ($T \propto 1/N$)➤ OR remains constant with speed ($T = N$)➤ OR increases with square of speed ($T \propto N^2$) <p>4. Electric Characteristics of drive:</p> <ul style="list-style-type: none">➤ Starting,➤ Running,➤ Speed control➤ and braking characteristics <p>of electric drive should be studied and it should be matched with load requirements(i.e. machine).</p> <p>5. Size and rating of motor:</p> <ul style="list-style-type: none">➤ Whether motor is short time running➤ OR continuously running➤ OR intermittently running➤ OR used for variable load cycle. <p>Whether overload capacity, pull out torque is sufficient.</p> <p>6. Mechanical Considerations:</p> <ul style="list-style-type: none">➤ Types of enclosure,➤ Types of bearing,➤ Transmission of mechanical power,➤ Noise➤ and load equalization <p>7. Cost:</p> <ul style="list-style-type: none">➤ Capital,➤ Running➤ and maintenance cost should be less.
b)	<p>State any two applications of each for the following types of electrical heating :</p> <p>(i) Direct resistance heating(ii) Indirect induction heating (iii) Direct.arc heating (iv) Dielectric heating</p>
Ans:	<p>(Any Two Application Are Expected Of Each Heating Type 1/2 Mark Each Application, Total 4 Marks)</p> <p>(i) Direct resistance heating:- (Any Two Application Are Expected)</p> <p>1. This type of heating used for industrial purpose</p>



2. Salt bath heating: This utilized for the purpose of carbonizing, tempering, quenching and hardening of steel tools
3. Heating of water in boiler

(ii) Indirect induction heating:

(Any Two Application Are Expected)

1. For heating as well as melting
2. Production of carbon free ferrous alloys.
3. For vacuum melting.
4. For melting non-ferrous metals for e.g. copper, aluminum, nickel etc.
5. For duplexing steel products.
6. Heating of non-conducting material is also possible if crucible is made from conducting material.

(iii) Direct arc heating:-

(Any Two Application Are Expected)

1. Used for continuous and large production of high quality steel.
2. For Ferro-alloy manufacturing

(iv) Dielectric heating:-

(Any Two Application Are Expected)

- 1) In food processing industry, dielectric heating is used for Baking of cakes & biscuits in bakeries.
- 2) Cooking of food without removing outer shell (e.g.-boiled egg) and pasteurizing of milk.
- 3) For Rubber vulcanizing.
- 4) In Tobacco manufacturing industry for dehydration of tobacco.
- 5) In wood industry for manufacturing of ply wood.
- 6) In plastic Industry for making different containers.
- 7) In cotton industry for drying & heating cotton cloths for different processes.
- 8) In tailoring industry for producing threads.



	<p>9) For manufacturing process of raincoats & umbrellas.</p> <p>10) In medical lines for sterilization of instruments & bandages.</p> <p>11) For heating of bones & tissues of body required for certain treatment to reduce pains & diseases.</p> <p>12) For removal of moisture from oil.</p> <p>13) For quick drying gum used for book binding purpose.</p> <p>14) In foundry for heating of sand, core, which are used in molding processes.</p>
c)	Define following terms referred to illumination : (i) Space-height ratio (ii) Utilization factor (iii) Maintenance factor (iv) Waste light factor
Ans:	<p>(Each Definition 1 Mark, Total 4 Mark)</p> <p>(i) Space-Height ratio:</p> $\text{Space height ratio} = \frac{\text{Space between lamps}}{\text{Height of lamps above working plane}}$ <p>(ii) Utilization factor:- It is defined as the ratio of total lumens reaching the working plane to the total lumens given out by the lamp. Its value is always less than one.</p> <p>(iii) Maintenance factor :- It is defined as the ratio of illumination under normal working conditions to the illumination when everything is clean.</p> <p style="text-align: center;">OR</p> $\text{Maintenance factor} = \frac{\text{Illumination under normal working condition}}{\text{Illumination under everything is clean}}$ <p>(iv) Waste light factor: When a surface is illuminated by several numbers of the sources of light, there is certain amount of waste due to overlapping of light waves, The waste of light is taken into account depending upon the type of area to be illuminated. The value of waste Light factor 1 to 1.5</p>



d)	State the four causes of low (poor) power factor.
Ans:	<p>(Any Four causes of low (poor) power factor From The Following Or Equivalent Points Are Expected 1 Mark To Each Point, Total 4 Marks)</p> <p><u>Following are the Causes of low power factor: -</u></p> <ol style="list-style-type: none">1. <u>Magnitude of Magnetizing Current (I_{μ}):-</u> As magnetizing current increases, power factor reduces.2. <u>Due to use of Induction Motor:-</u> Most of industrial drives, agriculture pumps, lift, irrigation pump set uses I.M. which works at lagging power factor, and so power factor reduces.3. <u>Due to use of Transformer: -</u> All transformers works at lagging power factor, so power factor of system reduces.4. <u>Due to welding transformer: -</u> Welding transformers are operated at low p.f. which reduces p.f. of the system.5. <u>Due to inductance of transmission & distribution Line: -</u> In case of AC transmission & distribution lines, inductance is present which the main cause of low power factor .6. <u>Series Reactor:-</u> Series reactor is used in substation to minimize fault current Which causes low power factor.7. <u>Industrial electrical heating furnaces:-</u> Induction and arc furnace used in steel manufacturing industry works at low p.f. which reduces p.f. of the system.8. <u>Arc Lamp:-</u> Arc lamp & electric discharge lamps operates at low p.f.so p.f. of the system reduces.9. <u>Equipments operated at light load:-</u> P.f. falls if equipments like alternator, transformer, I.M.etc are not operated at full load.10. <u>Improper repairs and maintenance:-</u> P.f. falls if proper maintenance or repairs of equipments are not done.

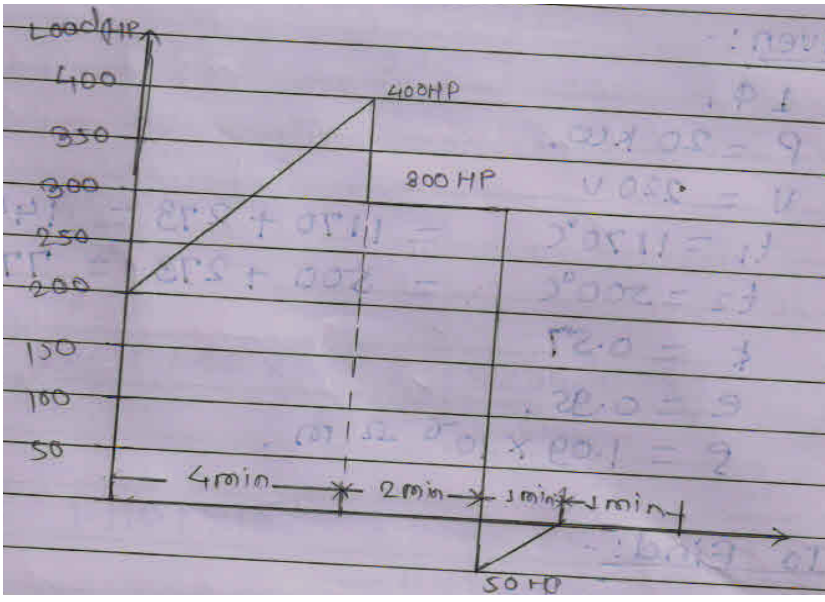

Q.1B)	Attempt any ONE :	(1x6=6)
a)	<p>Draw the graph load vs. time and estimate suitable HP rating of electric drive (motor) having following duty cycle : (i) Rising load from 200 to 400 HP : 4 minutes (ii) Uniform load of 300 HP : 2 minutes (iii) Regenerative braking from 50 to zero HP for : 1 minute (iv) Idle for :1 minute</p>	
Ans:	<p>(When Final answer of Numerical is correct Give Full Marks & if final answer is wrong give stepwise marks)</p> <p>Graph:</p> 	
		(2 Mark)
	<p>Duty Cycle (T) = t₁ + t₂ + t₃ + t₄ -----</p> <p style="text-align: center;">= 4+2+1+1</p> <p style="text-align: center;">= 8 Min. -----</p>	<p>(1/2 Marks)</p> <p>(1/2 Marks)</p>
	<p>Continuous rating of Motor:</p> $\text{rating of motor} = \sqrt{\frac{\frac{1}{3}(HP_1^2 + HP_2^2 + HP_1 HP_2)t_1 + (HP_3)^2 \times t_2 + \frac{1}{3}(HP_4^2 + HP_5^2 + HP_4 HP_5)T_3 + HP_6^2 + T_4}{T}}$ <p style="text-align: right;">(1 Mark)</p> $\text{rating of motor} = \sqrt{\frac{\frac{1}{3}(200^2 + 400^2 + 200 \times 400) \times 4 + (300)^2 \times 2 + \frac{1}{3}(50^2 + 0^2 + 50 \times 0)1 + 0^2 \times 1}{8}}$ <p style="text-align: center;">rating of motor = 263.193 HP -----</p> <p style="text-align: right;">(2 Mark)</p> <p style="text-align: center;">Nearest Standard rating of motor should be selected</p>	



b) Compare between Resistance welding and Arc welding on any six points.

Ans: (Any Six Points From The Following Or Equivalent Points Are Expected 1 Mark To Each Point, Total 6 Marks)

Sr.No	Parameters	Resistance Welding	Arc Welding
1	Type of welding	Plastic/Pressure/Non-fusion welding	Fusion/Non pressure welding
2	Principle of heat developed	Heat is developed due to I^2R losses where R is the contact resistance	Heat developed due to arc produced in between electrode and job
3	External filler material required	Not required during welding	Required during welding
4	External pressure required	Required	Not required
5	Type of supply used	Both AC,DC supply is used. But generally Ac Supply is used.	<u>Metal arc welding</u> – Both AC,DC supply is used. But generally Ac Supply is used.and for <u>Carbon arc welding</u> –only DC supply are used
6	Voltage & current required	Low voltage (2 to 20V AC) and high current (40 to 400A, in some cases 5 to 20KA) supply is required	<u>Metal Arc welding Voltage-</u> 70 to 100V AC and <u>Carbon arc welding voltage-</u> 50 to 60V DC, Current- 50-600-800A
7	Energy consumption	Low (3 to 4 KWH/Kg of	High (5 to 10 KWH/Kg of



		deposited material)	deposited material.)
8	Temperature obtained	Temperature obtained is not very high (up to 1350 ⁰ C)	Temperature obtained is very high (up to 3500 ⁰ C to 6000 ⁰ C)
9	Power factor	Low	Poor
10	Type of electrode	Non-consumable electrodes are used.	Coated electrodes are used for metal arc welding and bare electrodes are used for carbon arc welding.(Electrodes may be consumable or non-consumable)
1.	Application	It is suitable for mass production	It is suitable for heavy job, maintenance and repair work

Q.2 **Attempt any FOUR :** (4x4=16 Mark)

a) State four advantages and four disadvantages of electrical braking over mechanical braking.

Ans: (Any Four Points From The Following Or Equivalent Points Are Expected For Advantages 1/2 Mark To Each Point, Total 2 Marks & For Disadvantages 1/2 Mark To Each Point, Total 2 Marks, Total 4 Marks)

Following are the advantages & disadvantages of electrical braking over mechanical braking system.

Advantages: (Any Four Points From The Following Or Equivalent Points Are Expected)

1. It is most reliable braking system.
2. Breaking actuation time is small as higher value of braking retardation is obtained.
3. Electrical braking is smooth & gradual.
4. Life of electrical braking system is more.
5. There is less wear & tear of brake shoes, break block etc. so there is less maintenance cost.
6. Higher speeds are possible even when train is going down the gradient, as breaking system is reliable.
7. Trains having heavy loads can be stopped even when train going up the gradient.



	<p>8. Higher speeds of train is possible as braking system is reliable so pay load capacity increases.</p> <p>9. In case of electric regenerative braking we can utilize 60 to 80% of kinetic energy to generate electricity which is not possible with mechanical braking.</p> <p>Disadvantages: (Any Four Points From The Following Or Equivalent Points Are Expected)</p> <ol style="list-style-type: none">1. In addition to electrical braking there must be arrangement of mechanical braking for final stop.2. Special arrangement of circuit and complication makes electrical braking system costly.3. Operation in substation becomes complicated at the time of regenerative breaking when generated energy is surplus.4. Initial cost is more due to other control equipments & circuitry.
b)	Derive an expression for design of heating element when heating element is circular wire.
Ans:	<p>(Derivation up to equation 1 or part I--- 2Marks & For equation 2 or part II---2 Marks, Total 4 Marks)</p> <p>Let,</p> <p>P = electrical Input in watt (w)</p> <p>V = Supply voltage in V</p> <p>I = Currents in Amp</p> <p>R= Resistance of heating element in Ω</p> <p>ρ = Specific resistivity in Ω/m</p> <p>l = length of heating element in m</p> <p>a = Cross section of heating element in m^2</p> <p>d = Diameter of heating element in m</p> <p>Part-I:</p> $P = V I$ <p>But , $I = \frac{V}{R}$</p> $P = \frac{V \times V}{R}$



$$P = \frac{V^2}{R} \text{----- (A)}$$

But,

$$R = \frac{\rho \times l}{a} \quad \text{and} \quad a = \frac{\pi}{4} \times d^2$$

$$R = \frac{4 \rho \times l}{\pi d^2}$$

Now Substitute value of 'R' in equation (A)

$$\therefore P = \frac{V^2 \times \pi d^2}{4 \rho l}$$

Rearranged above equation,

$$\therefore \frac{1}{d^2} = \frac{V^2 \pi}{4 P \rho}$$

-----Equation I

Part-II:

When steady temperature is reached, electrical input is equal to heat output

Electrical input = Heat output

$$P = H \text{ (Surface area)}$$

Surface area of circular heating element = $\pi d l$

$$P = H (\pi d l)$$

Now substitute the value of "P"

$$\therefore \frac{V^2 \times \pi d^2}{4 \rho l} = H (\pi d l)$$

Rearranging above equation

$$\therefore \frac{d}{l^2} = \frac{4 \rho H}{V^2}$$



$$\therefore \frac{d}{l^2} = \frac{4 \rho H}{V^2}$$

-----Equation II

From equation I and II we can calculate length & diameter of heating element.

c) **State eight requirements of an ideal traction system.**

Ans: **(Any Eight Points From The Following Or Equivalent Points Are Expected 1/2 Mark To Each Point, Total 4 Marks)**

Ideal Traction system should processes following requirement:-

1. It should be Pollution free.
2. It should have low capital, Running and maintenance cost.
3. It should have quick starting time.
4. It should have high starting torque.
5. It should have high rate of acceleration & retardation.
6. Highest speeds are possible.
7. It should have easy speed control method.
8. Its braking system should be reliable and causes less wear.
9. It should have better riding quality (less vibration)
10. It should be free from unbalance forces i.e. coefficient of adhesion should be more.
11. It should have lower center of gravity.
12. The locomotive should be self-contained and able to run on any route
13. There should be no standby losses.
14. It should have high efficiency
15. Regenerative braking should be possible.
16. The wear caused on the track should be minimum.



	<p>17. Equipment should be capable of overloads for short periods.</p> <p>18. Capability of withstanding voltage fluctuations.</p> <p>19. Parallel running usually more than one motor (2 or 4 motors) should be possible.</p> <p>20. Traction system should be clean & long life.</p> <p>21. There should be no interference to the communication lines running along the lines.</p>
d)	State various systems of track electrification.
Ans:	<p>(Any Four Systems Of Track Electrification From The Following Are Expected 1 Mark To Each Systems Of Track Electrification, Total 4 Marks)</p> <p>Following are the different track electrification system</p> <p>D.C. Supply system:-</p> <ol style="list-style-type: none">1. Direct current track electrification:<ul style="list-style-type: none">➤ 600V, 750V DC for tramways➤ 1500V, 3000V DC for Train (Urban and sub-urban services) <p>A.C. Supply system:-</p> <ol style="list-style-type: none">2. 1-Ph, 25KV, standard frequency AC supply system:<ul style="list-style-type: none">➤ 1-Ph, 25 KV, 50 Hz3. 1-Phase, low frequency AC Supply system:<ul style="list-style-type: none">➤ 1-Ph, 15/16 KV, 16.2/3 Hz or 25 Hz4. 3-Ph, Low frequency AC supply system;<ul style="list-style-type: none">➤ 3-Ph, 3.3/3.7 KV, 16 2/3 Hz or 25 Hz <p>Composite system:-</p> <ol style="list-style-type: none">5. 1-Ph AC (1-ph, 25KV) – DC Supply System6. Kando System (1-Ph AC – 3-Ph AC)



e)	Compare between urban line, sub-urban line and mainline services on following points : (i) Distance between two Railway Station. (ii) Acceleration (iii) Retardation (iv) Maximum Speed (v) Specific energy consumption (vi) Free running period absent or present (vii) Coasting period absent or present (viii) Shape of speed time curve				
Ans:	(Eight Points From The Following Are Expected 1/2 Mark To Each Point, Total 4 Marks)				
	Sr.No	Points	Urban line services	Suburban line services	Main line services
	1.	Distance between two railway station	Low (1km)	Medium (2.5 to 3 km)	High (above10km)
	2.	Acceleration (α)	High $\alpha = 1.5$ to 4 km/hr-sec	High $\alpha = 1.5$ to 4 km/hr-sec	low $\alpha = 0.6$ to 0.8km/hr-sec
	3.	Retardation (β)	High $\beta = 3$ to 4 km/hr-sec	High $\beta = 3$ to 4 km/hr-sec	low $\beta = 1.5$ km/hr-sec
	4.	Maximum Speed	120 km / hr	120 km / hr	160 km / hr
	5.	Specific energy consumption	High = 50 to 75 watt-hr/tonne-km	High = 50 to 75 watt-hr/tonne-km	Low = 18 to 31 watt-hr/tonne-km
	6.	Free running period	Free running period is absent	Free running period is absent	Free running period Present / long
	7.	Coasting period	Coasting period is Present/small	Coasting period is Present/small	Coasting period is Present/long.
	8.	Shape of speed-time	Quadrilateral	Quadrilateral	Trapezoidal



Q.3	Attempt any TWO : (2 x 8 =16 Marks)
a) i)	State the factors to be considered for selection of shape and size of the car of the elevator.
Ans:	<p>(Any Four Points From The Following Or Equivalent Points Are Expected 1 Mark To Each Point, Total 4 Marks)</p> <p>The size and shape of elevator car depends on following factors:</p> <p>i) No. of passenger to be carried: While selecting the size of car it is a usual practice to allow.</p> <ul style="list-style-type: none">➤ A Space of 2 Sq.ft/ person.➤ Average weight of passenger is assumed 68 kg/person.➤ Thus the maximum load capacity of elevator is considered 34 kg/sq.ft➤ There should be wide frontage and shallow depth <p>ii) Limitation in the building design:</p> <ul style="list-style-type: none">➤ Shape of elevator depends on space available in building. <p>iii) Type of building</p> <p>iv) Application of elevator</p>
a) ii)	Draw graphical representation of load cycle : (i) Continuous loading (ii) Short time loading (iii) Long time (intermittent) loading (iv) Continuous operation with short time loading
Ans:	<p>(Each graphical representation of load cycle 1 Mark Each, Total 4 Marks)</p> <p>(i) Continuous loading:-</p> <div data-bbox="435 1417 1075 1843" data-label="Figure"></div> <p style="text-align: right;">or equivalent figure</p>



(ii) Short time loading:-

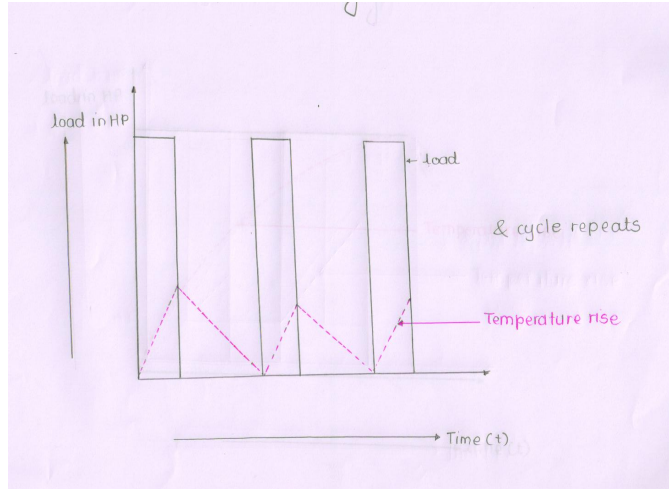

or equivalent figure

(iii) Long time (intermittent) loading:-

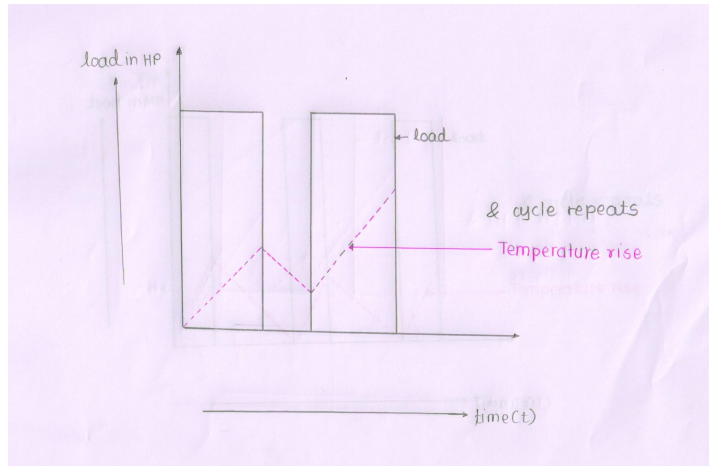

or equivalent figure

(iv) Continuous operation with short time loading:-

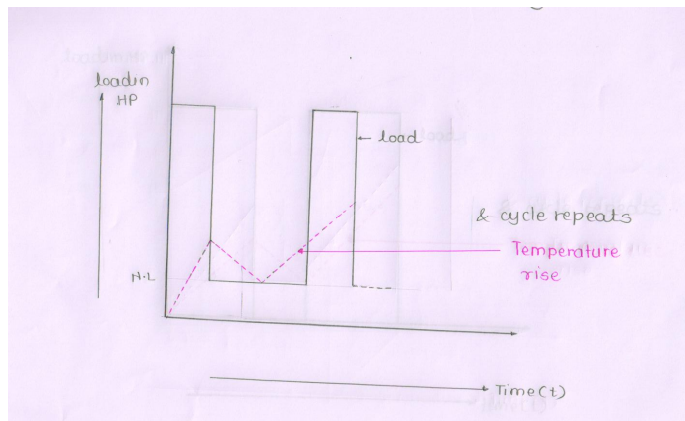

or equivalent figure



b)	<p>A 20 kW single phase 220 V resistance oven employs a circular nichrome wire for its heating element. If wire temperature is not to exceed 1170 °C and temperature of charge is to be 500 °C. Calculate diameter and the length of wire. Take $k = 0.57$, $e = 0.95$ and Resistivity = 1.09×10^{-6} ohm-mtz.</p>
Ans:	<p style="text-align: center;">(When Final answer of Numerical is correct Give Full Marks & if final answer is wrong give stepwise marks)</p> <p>Given Data:</p> <p>$T_1 = 1170^{\circ}\text{C} = 1170 + 273 = 1443^{\circ}\text{K}$ ----- (1/2 Mark)</p> <p>$T_2 = 500^{\circ}\text{C} = 500 + 273 = 773^{\circ}\text{K}$ ----- (1/2 Mark)</p> <p>Radiation efficiency = 0.57, specific resistance of Ni-Cr = 1.09×10^{-6} ohm m, emissivity = 0.95.</p> <p>$H = 5.72 \times 10^4 k.e \left[\left(\frac{T_1}{1000} \right)^4 - \left(\frac{T_2}{1000} \right)^4 \right] \text{ w/m}^2$ OR</p> <p>$H = 5.72 \times k.e \left[\left(\frac{T_1}{100} \right)^4 - \left(\frac{T_2}{100} \right)^4 \right] \text{ w/m}^2$ ----- (1 Mark)</p> <p>$H = 5.72 \times 0.57 \times 0.95 \left[\left(\frac{1443}{100} \right)^4 - \left(\frac{773}{100} \right)^4 \right] \text{ w/m}^2$</p> <p>$H = 123236.0773 \text{ w/m}^2$ ----- (1 Mark)</p> <p>➤ $\therefore \frac{l}{d^2} = \frac{V^2 \pi}{4 P \rho}$ ----- Equation No.1 ----- (1 Mark)</p> <p>$\therefore \frac{l}{d^2} = \frac{(220)^2 \pi}{4 \times 20 \times 1000 \times 1.09 \times 10^{-6}}$</p> <p>$\therefore \frac{l}{d^2} = 1743728.032$</p> <p>$l = 1743728.032 d^2$ ----- Equation No.2 ----- (1 Mark)</p>



WINTER– 2017 Examinations

Subject Code: 17507

Model Answer

Page 17 of 35

	$\frac{d}{l^2} = \frac{4\rho H}{V^2}$ $\frac{d}{l^2} = \frac{4 \times 1.09 \times 10^{-6} \times 123236.0773}{(220)^2}$ $\frac{d}{l^2} = 1.1101 \times 10^{-5}$ $d = 1.1101 \times 10^{-5} \times [1743728.032d^2]^2$ $d = 33754874.07 \times d^4$ $\frac{d}{d^4} = 33754874.07$ $\frac{1}{d^3} = 33754874.07$ $d^3 = 2.9625 \times 10^{-8}$ <p>Taking Cube root of both sides</p> $d = 3.0942 \times 10^{-3} m$ <p style="text-align: right;">----- (1Mark)</p> $d = 3.0942 mm$ <p>Substitute Value of 'd' in Equation No.2 to calculate 'l' :</p> $l = 1743728.032d^2$ <p style="text-align: right;">----- (1 Mark)</p> $l = 1743728.032 \times [3.0942 \times 10^{-3}]^2$ $l = 16.69m$ <p style="text-align: right;">----- (1 Mark)</p> <div style="border: 1px solid black; padding: 5px; margin-top: 10px;"> <p>Answer : \therefore Length $l = 16.69 mtr$ \therefore Diameter $d = 3.0942 mm$</p> </div>
--	---

c) i)	Compare individual and group drive on any four points.			
Ans:	(Any Four Points From The Following Or Equivalent Points Are Expected 1 Mark To Each Point, Total 4 Marks)			
	S.No.	Point	Individual Drive	Group Drive
	1.	Definition	In this type of drive each machine has its own separate electric drive (motor). It may be directly coupled or indirectly coupled	In a group drive single large capacity electric drives is used to run number of machines through a long common shaft.
	2.	Initial Cost	High	Less



3.	Flexibility	More Flexibility	Less Flexibility
4.	Safety	It is more safe	It is less Safe
5.	Reliability	It has high reliability	It has less reliability
6.	Space required	More	Less
7.	Overload Capacity	Less	Higher
8.	Maintenance cost	More	Less
9.	Speed control	Easily possible	Difficult
10.	Mechanical Power transmission losses	Less losses	More Losses
11.	Addition/Alternation	Easily possible	Easily not possible
12.	Total HP	More	Less
13.	Appearance	Good	Not good
14.	Any one application of each	Lathe Machine (Similar application will be consider)	Textile Industry (Similar application will be consider)

c) ii) **Why noise of motor is produced? How it can be reduced?**

Ans: (Any Two Points From The Following Or Equivalent Points Are Expected, 1 Mark each point Total 2 Marks)

Noise of motor is produced due to:-

1. Vibration
2. Bad foundation
3. Friction
4. Magnetic pulsation

(Any Two Points From The Following Or Equivalent Points Are Expected, 1 Mark each point, Total 2 Marks)

Noise of motor can be reduced by –

1. Motor is mounted on cushion such as rubber pad instead of direct mounting on concrete foundation.
2. Motor can be mounted on spring so that it can absorb all the vibrating frequency.
3. By proper maintenance i.e. if bearings are worn out then replace it.

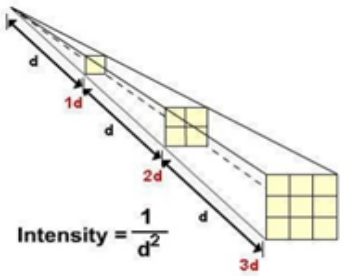

	<p>4. Lubrication must be done regularly.</p> <p>5. Electrical connection to motor should be given through PVC flexible pipe instead of metal flexible pipe.</p> <p>6. By connecting condenser of 0.1 to 0.25 microfarad across live and motor frame (earth) which will reduce magnetic pulsation. Also it will reduce radio interference</p>
Q.4A)	Attempt any THREE : (3 x 4 =12 Marks)
a)	Give classification of electrical welding.
Ans:	<p style="text-align: right;">(Total 4 Marks)</p> <p>i) <u>Resistance Welding</u>:-</p> <ul style="list-style-type: none">1) Spot welding2) Seam welding3) Projection Welding4) Butt Welding- i) Simple butt welding ii) Flash butt welding <p>ii) <u>Arc welding</u>:-</p> <ul style="list-style-type: none">1) Carbon Arc Welding: a) shielded welding b) unshielded welding2) Metal Arc Welding: a) shielded welding b) unshielded welding
b)	State the two laws of illumination.
	<p>(Inverse Square Law :- 2 Marks , Lamberts Cosine Law:- 2 Marks)</p>
Ans:	<p>1) Inverse Square Law:-</p> <p>Intensity of illumination produced by a point source varies inversely as square of the distance from source.</p>  <p style="text-align: center;">$Intensity = \frac{1}{d^2}$</p> <p style="text-align: center;">$E = \frac{I}{d^2}$</p> <p>Where,</p> <p style="text-align: center;">I = intensity and d = Distance</p>



2) Lamberts Cosine Law:

According to this law, Illumination at any point on a surface is proportional to the cosine of the angle between the normal at that point and the direction of luminous flux

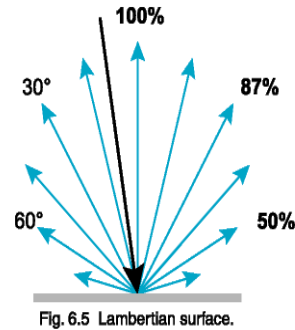
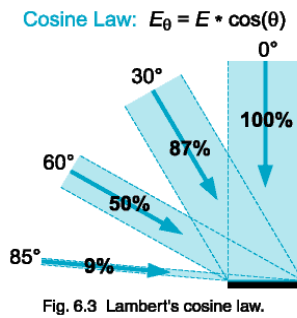

OR

Following two tariffs are offered to consumers :

- c) (i) Rs. 150 + 20 paise per unit. (ii) A flat rate of 40 paise per unit. State at what consumption which tariff is economical.

Ans:

(When Final answer of Numerical is correct Give Full Marks & if final answer is wrong give stepwise marks)

Given data: Two tariffs

- (i) Rs. 150 + 20 paise per unit (ii) A flat rate of 40 paise per unit

Let 'X' be energy consumption when both tariff give same energy bill:

$$Rs. 150 + \frac{20}{100} X = \frac{40}{100} X$$

$$Rs. 150 \times 0.2X = 0.4X$$

$$Rs. 150 = 0.4X - 0.2X$$

$$X = \frac{150}{0.2}$$

$$X = 750 \text{ KWH} \text{ -----}$$

(2 Marks)



	<p>➤ State at what consumption which tariff is economical-----(2 Marks)</p> <p>When energy consumption is greater than 750 Kwh the tariff one i.e. Rs. 150 + 20 paise/unit is economical when energy consumption is less than 750 Kwh than tariff Two i.e. flat rate 40 paise per unit is economical.</p>
d)	<p>State disadvantages of low power factor.</p>
Ans:	<p>(Any Four Points From The Following Or Equivalent Points Are Expected 1 Mark To Each Point, Total 4 Marks)</p> <p>Disadvantages of Low power Factor: -</p> <p>1) Cross section of conductor increases: -</p> <p>As power factor reduces current increases, cross section of conductor increases. Hence its cost increases.</p> <p>2) Design of supporting structure: -</p> <p>As power factor reduces, cross section of conductor increases, so its weight increases. To handle this weight design of supporting structure becomes heavier, so its cost increases.</p> <p>3) Cross section of terminals increases: -</p> <p>As power factor reduces, current increases, Hence cross section of switch gear, bus bar, contacts, and terminals increases. So its cost increases.</p> <p>4) Copper losses increases: -</p> <p>As power factor reduces current increases. So copper losses increases. As an effect efficiency reduces.</p> <p>5) Voltage drop increases: -</p> <p>As P.F. reduces current increases. Therefore voltage drop increases, so regulation becomes poor.</p> <p>6) Handling Capacity of equipment reduces:</p> <p>Handling capacity (KW) of each equipment such as Alternator, transformer reduces as power factor reduces. e.g.</p> <p>6) High KVA rating of equipment required:-</p> <p>As power factor decreases KVA rating of all equipment's increases, so that its cost increases.</p> <p>7) Cost/unit increases: - From all above disadvantages it is seen that cost of generation, transmission & distribution increases. Also its performance efficiency & regulation reduces, So that cost/unit increases.</p>



Q. 4 B)	Solve any ONE of the following	06 Marks
a)	Draw figure of (i) Seam welding and (ii) Flash Butt welding and write two applications of each type.	
Ans:	<p>(figure of (i) Seam welding – 2 Marks, Application any Two 1/2 Mark each, figure of (ii) Flash Butt welding– 2 Marks, Application any Two 1/2 Mark each)</p> <p>(i) Seam welding: (Figure- 2 Mark)</p> <div data-bbox="397 642 1096 1050" data-label="Diagram"><p>or equivalent figure</p></div> <p>Applications of Seam welding:- (Any Two Applications Are Expected ½ Mark Each, Total 1 Mark)</p> <p>It gives leak-proof joints.</p> <ol style="list-style-type: none">1. Hence used for welding of various types of containers,2. Pressure tank,3. Tank of transformer,4. Gas line,5. Air craft tank,6. Condenser,7. Evaporator and8. Refrigerator etc.	



(ii) Flash Butt welding:-

(Figure- 2 Mark)

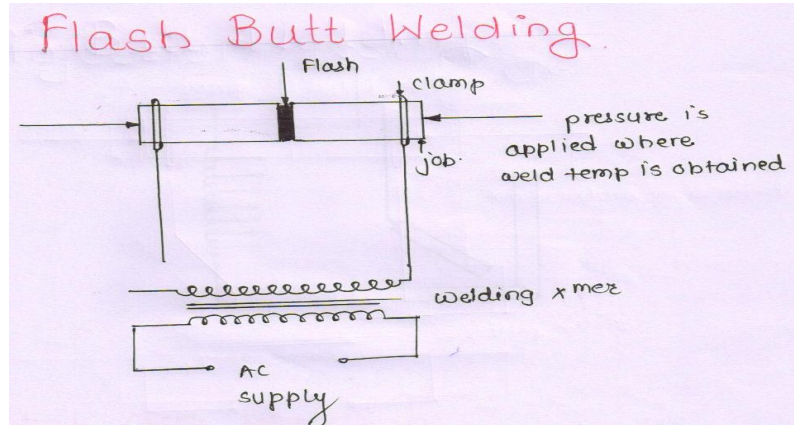

Application Flash Butt welding: (Any Two Applications Are Expected ½ Mark Each, Total 1 Mark)

1. For welding rod.
2. For weld shaft
3. Rail, ends
4. For welding chains

b) i) i) State the four requirements of Tariff.

Ans: **Any Four Requirements From The Following Or Equivalent Points Are Expected , Total 3 Marks)**

Following are the requirements of Tariff :-

1. It should be easy to understand to consumer.
2. Easy to calculate.
3. Tariff should be attractive i.e. It should not be too high or too low. It should be reasonable.
4. Tariff should be economical as compare to other types of energy sources.
5. Tariff should be different for different types of consumers.
6. Tariff must be fair, so that different types of consumers are satisfied with rate of electrical energy charges.
7. Tariff should be framed into two parts i.e. fixed charges + running charges.



	<p>8. Tariff should be high during peak load period.</p> <p>9. Tariff should be low during off load period.</p> <p>10. For industrial consumer, in addition to basic tariff incentives and penalty related to PF and LF should be considered.</p>
b) ii)	State two advantages of P.F. tariff and TOD tariff for the power system concern
Ans:	<p>(P.F. tariff advantages---- 1.5Marks & TOD tariff advantages---- 1.5Marks)</p> <p>Advantages of P.F. tariff for the power system concern:-</p> <p>(Any Two Advantages are Expected, 1.5 Marks)</p> <p>Advantages:-</p> <ol style="list-style-type: none">1) Industrial consumers were trying to run their industry above 0.95lagging power factor (At High P.F.) To get discount in energy bill, so overall P.F. of power system increases.2) As each industry run at high power factor then overall power factor of power system increases. Due to this3) Which will automatically beneficial from the economics of power system <p>Because at high power factor :-</p> <p><u>Generation has following advantages:</u></p> <ol style="list-style-type: none">a) Low KVA rating of equipment (alternator) is required.b) Handling capacity of equipment (alternator) increases.c) Cost per unit decreases. <p><u>Transmission has following advantages:</u></p> <ol style="list-style-type: none">a) Low KVA rating of equipment (Transformer) is required.b) Handling capacity of equipment (Transformer) increases.c) Cost of conductor decreases.d) Cost of supporting structure decreases.e) Copper losses increasesf) Transmission efficiency increases.



- g) Voltage drop in transmission line decreases.
h) Regulation gets improved

Advantages of TOD tariff for the power system concern:-

(Any Two Advantages are Expected, 1.5 Marks)

Advantages:

1. Major industrial consumers are trying to run their maximum load during OFF load period, to get rebate in their energy bill.
2. Major industrial consumers are trying to run their industry at reduced load during PEAK load period to avoid additional charges charged in energy bill.
3. Due to above two reasons, it increases overall load factor as well as diversity factor of power system.
4. As load factor and diversity factor of power system increases so overall cost per unit reduces.
5. Also due to this there will be maximum utilization of power plant & infrastructure.
So, TOD tariff helps to avoid the wastage of surplus energy generated during OFF load period.
In this way it helps to conserve energy.

Q.5 Attempt any FOUR : (4 x4=16 Marks)

a) **Compare sodium vapour lamp and metal halide lamp on following points : (i) Luminous efficiency, (ii) life of lamp, (iii) re-strike time, (iv) cost of installation.**

Ans: **(Each Point 1 Mark, Total 4 Marks)**

Sr. NO.	Point	Sodium vapour lamp	Metal halide lamp
1.	Luminous efficiency	Luminous efficiency Lm/w 80-100	Luminous efficiency Lm/w 50-100
2.	Life of lamp	Life more 12000-16000 hrs.	Life less than SV lamp 12000 hrs.
3.	Re-strike time	Less Than MH lamp (2 To 5 min.)	More than SV lamp (5 To 10 min.)
4.	Cost of installation	Less Than MH lamp	More than SV lamp



<p>b) Ans:</p>	<p>State any factors to be considered while selecting electrical welding system. (Any Four Factors From The Following Or Equivalent Points Are Expected 1Mark To Each Point , Total 4 Marks)</p> <p>Following Factors are considered while selecting of electric welding system:-</p> <p>1) <u>Type of Material:-</u> Whether similar metal is to be welded or dis-similar metal is to be welded.</p> <p>2) <u>Property of Material:-</u> Whether ferrous or non-ferrous metal is to be welded.</p> <p>3) <u>Thickness of job:-</u> It is also depends on thickness of job to be welded. e.g. for thick material- Arc welding is used. And for thin material – Resistance welding is used.</p> <p>4) <u>Temperature required:-</u> Whether job required high or low temperature to weld the job. e.g. For high Temperature - Arc welding is used. And for low Temperature – Resistance welding is used.</p> <p>5) <u>Pressure required:-</u> If job is need of pressure at the time of welding in that case resistance welding is used. And if pressure is not required Arc welding is used.</p> <p>6) <u>Type of Supply Available:-</u> Whether AC or DC or both supply are available.</p> <p>7) <u>Application:-</u> In case of mass production, resistance welding is used & for repair work Arc welding is used.</p>
--------------------	---



c) Sketch the various steps required for bridge transition system.

Ans:

(Each Step 1 Mark, Total 4 Marks)

In bridge transition, series last step to parallel first step, is carried out by following steps

Step1: Bridge link is connected between two motors as shown in figure (Series last step)

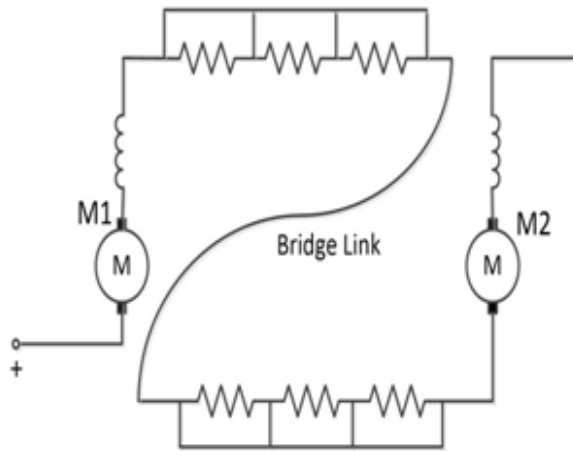

Step2: Bridge link is so rotated that two motors are put in series without starting resistance. Which are un-shorted at the same time.

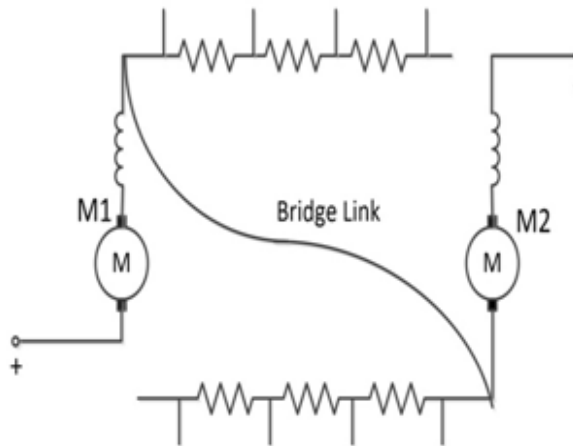



Step 3: The portions of external resistance are connected in each motor circuit as shown in fig

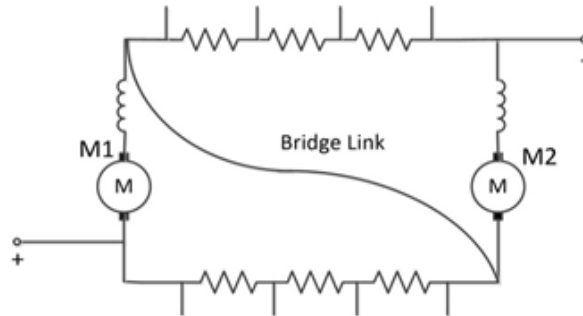

Step 4: In this last step bridge link is removed as shown in fig. This is nothing but parallel first step.

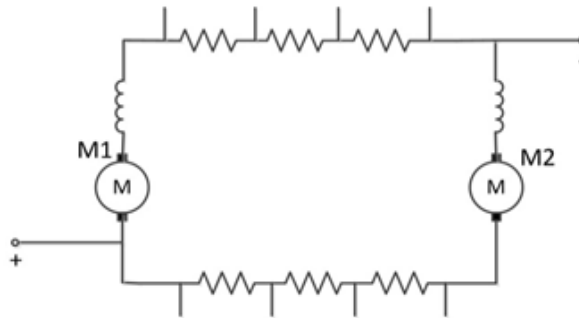

d) Compare AC and DC system of track electrification on any four points.

Ans:

(Any Four point expected: 1 Mark each, Total 4 Marks)

S.No	Points	AC System Traction	DC System Traction
1.	Supply given to O/H condition	1-ph, 25KV, AC 50 Hz	600/750V-Tromways 1500/3000V urban/suburban
2.	Type of drive used	1-ph, AC series motor	DC series motor for tramways. DC compound motor
3.	Weight of traction motor	1.5 times more than d.c. series motor.	1.5 times less than a.c series motor
4.	Starting torque	Less starting torque than d.c series motor	High starting torque
5.	Accel ⁿ and retardation	Less than d.c series motor	High
6.	Overload capacity	Less than d.c series motor	High
7.	Method of speed control	Simple and smooth	Limited, except chopper method



8.	Maintenance cost of traction motor	More	Less
9.	Starting Efficiency	More	Less
10	Ridding quality	Less, better than d.c.	Smooth (Better)
11	Insulation cost	High	Low
12	Cross section of conductor	Less	More
13	Design of supporting structure	light	Heavy
14	Distance between two substation	More	Less
15	No. of substation required for same track distance.	Less	More
16	Size (capacity) of traction substation	More	Less
17	Capital & maintenance cost of substation	Less	More
18	Cost track electrification for same track distance	Less	More
19	Applications	Main line services	Urban and suburban area

e) State any four desirable characteristics of ideal traction motor. State the names of different traction motor used.

Ans: **(Any Four Points From The Following Or Equivalent Points Are Expected ½ Mark To Each Point, Name of any two motors 1 Mark Each, Total 4 Marks)**

Desirable characteristics of ideal traction motors:-

(Any Four Points From The Following, Total 2 Marks)

A) Mechanical Properties or characteristics:

- 1) It should be robust in construction to withstand against continuous vibrations.
- 2) Weight of motor per HP should be minimum in order to increase pay load capacity.



- 3) It must be small in overall dimensions, especially in overall diameter.
- 4) It must have totally enclosed type enclosure to provide protection against entry of dirt, dust, mud, water etc. in drive.
- 5) When motors are running in parallel they should share almost equal load. (even when there is unequal wear & tear of driving wheels)

B) Electrical Properties or characteristics:

- 6) It should have high starting torque.
- 7) It should possess high rate of acceleration & retardation.
- 8) It should be variable speed motor.
- 9) Its speed-torque characteristics should be such that it should produce high torque at low speed and low torque at high speed.
- 10) Motor must be capable of taking excessive overload in case of emergency.
- 11) It should have simple speed control methods.
- 12) Electrical braking system should be reliable, easy to operate and control, especially regenerative braking is possible.
- 13) Motor should draw low inrush current (Starting current, and if supply is interrupted and restore again.)
- 14) It should withstand for voltage fluctuation without affecting its performance.

C) General Properties or characteristics:

- 19) It should have low initial cost.
- 20) It should have less maintenance cost.
- 21) It should have high efficiency.



	<p>22) It should have long life.</p> <p>Some of the motors which find application are- (Any Two Names of Motors From The Following, Total 2 Marks)</p> <ol style="list-style-type: none">1. DC Series Motor2. 1-Ph, AC series motor3. 3-Ph, Slip-ring induction motor4. Linear induction motor (LIM)
Q.6	Attempt any TWO of the following : 16 Marks
a) i)	Give the definition of (1) Average Speed, (2) Schedule speed in a traction system.
Ans:	<p>(Each Definition 2 Marks, Total 4 Marks)</p> <p>1. Average Speed: - It is defined as distance covered between two stops divided by actual time of run is known as average speed. OR</p> $V_{av} = \frac{3600D}{T} \text{ Km/hr}$ <p>Where T = is actual time of run in sec OR</p> $\text{Average Speed} = \frac{\text{Distance between stops or stations}}{\text{Actual time of run}}$ <p>2. Schedule Speed: - It is defined as distance covered between two stops divided by schedule time is known as schedule speed. OR</p> $\text{Schedule Speed} = \frac{\text{Distance between stops or stations}}{(\text{Actual time of run}) + (\text{Stop time})} \text{ Km/hr}$ <p>OR</p> $\text{Schedule Speed} = \frac{\text{Distance between stops or stations}}{\text{Schedule time}}$
a) ii)	Draw figure of indirect arc furnace. State why indirect arc furnace is not built of large capacity.
Ans:	<p>(Fig. 2 Marks & why indirect arc furnace is not built of large capacity- 2 Mark, Total 4 Marks)</p> <p>Figure of indirect arc furnace:-</p>

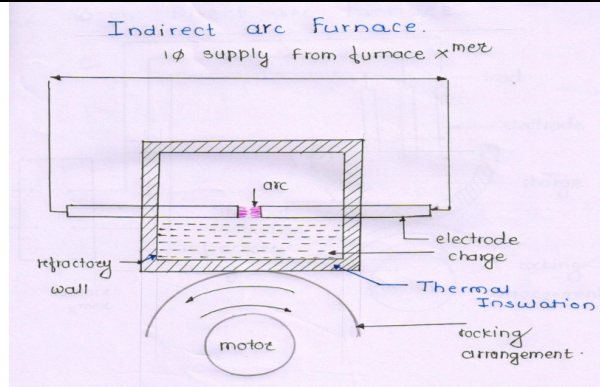

Why indirect arc furnace is not built of large capacity:-

- Shape of heating chamber is more cylindrical to make rocking easily.
- Due to this cylindrical construction of heating chamber there is limited to use only two electrodes.
- So this furnace is available only to use single phase supply & power handling capacity of 1-ph supply is less than 3-ph supply.

Hence indirect arc furnace is not built on large capacity

OR

Credit may be given by judgment on part of relevant answer based on candidate understanding.

- b) A train runs between two station is 2 km apart at average speed of 40 kmphr. Train accelerates at 2 kmphrsec. and retards at 3 kmphrsec. Assume trapezoidal speed time curve. Calculate: (i) Draw speed time curve and mark all. (ii) Maximum speed (iii) Distance travelled by train before the breaks are applied.

Ans: **(When Final answer of Numerical is correct Give Full Marks & if final answer is wrong give stepwise marks)**

Given Data: Acceleration $\alpha = 2$ km phps , Retardation $\beta = 3$ km phps , $D = 2$ Km. , $V_{av} = 40$ Kmph

Draw speed time curve and mark all :- (Speed Time Curve --- 3 Marks)

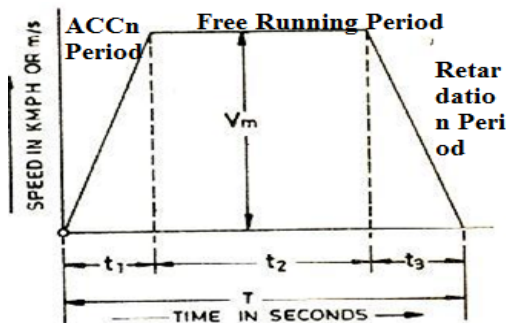

OR

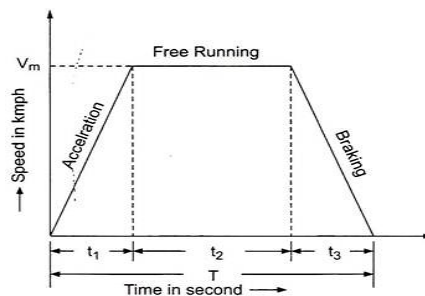

Fig. 7.2 Trapezoidal Speed-time Curve



To Calculate Maximum Speed :- (--- 4 Marks)

$$\text{But, } K = \frac{\alpha + \beta}{2(\alpha \times \beta)} \quad \text{----- (1 Mark)}$$

$$K = \frac{2 + 3}{2(2 \times 3)}$$

$$= 0.4167$$

$$V_{av} = \frac{3600 D}{\text{Time}} \quad \text{----- (1 Mark)}$$

$$40 = \frac{3600 \times 2}{\text{Time}}$$

$$\text{Time} = 180 \text{ sec.}$$

$$V_{\max} = \frac{T - \sqrt{T^2 - 4K3600D}}{2K} \quad \text{----- (2 Mark)}$$

$$V_{\max} = \frac{180 - \sqrt{180^2 - 4 \times 0.4167 \times 3600 \times 2}}{2 \times 0.4167}$$

$$= 44.6061 \text{ kmph}$$

To calculate Distance Travelled by train before breaks are applied:- (1 Mark)

Distance covered during Retardation ($D\beta$) =

$$D\beta = \frac{V_{\max}^2}{7200\beta}$$

$$D\beta = \frac{(44.6061)^2}{7200 \times 3}$$

$$D\beta = 0.0921 \text{ km}$$

Distance Travelled by train before breaks are applied :-

$$= D - D\beta =$$

$$= 2 - 0.0921$$

$$= 1.9079 \text{ Km.}$$



c)	<p>A three phase, 440 V, 50 Hz, 40 kW load has a P.F. 0.85 lagging. Calculate kVAR rating of capacitor required to improve P.F. to 0.95 lagging. What will value of capacitor per phase, if (i) capacitors connected in Star? (ii) Capacitors connected in Delta?</p>
Ans:	<p style="text-align: center;">(When Final answer of Numerical is correct Give Full Marks & if final answer is wrong give stepwise marks)</p> <p>Given Data</p> <p>Volt : 440 V, f= 50 Hz P= 40 Kw cos ϕ_1=0.85 cos ϕ_2=0.95 $\therefore \cos \phi_1 = 0.85$</p> <p style="text-align: right;">tan $\phi_1 = 0.6197$ ----- (1/2 Mark)</p> <p style="text-align: right;">cos $\phi_2 = 0.95$ tan $\phi_2 = 0.3286$ ----- (1/2 Mark)</p> <p style="text-align: right;">Q₁ = P tan ϕ_1 = 300 x 0.6197 = 24.788 KVAR ----- (1/2 Mark)</p> <p style="text-align: right;">Q₂ = P tan ϕ_2 = 300 x 0.3286 = 13.144 KVAR ----- (1/2 Mark)</p> <p>i) KVAR Rating of the capacitor Bank</p> <p style="text-align: right;">Q_C = Q₁ - Q₂ = P tan ϕ_1 - P tan ϕ_2 ----- (1 Mark) = 24.788 - 13.144 Q_C = 11.644 KVAR ----- (1 Mark)</p> <p>\therefore Capacitor when connected in Star :-</p> <p style="text-align: right;">$C \text{ per phase} = \frac{Q_C \times 10^3}{\omega V^2}$ or $Q_C = 2 \pi F_C V^2$ - ----- (1 Mark)</p>



$$C \text{ per phase} = \frac{11.644 \times 10^3}{2\pi \times 50 \times (440)^2}$$

$$C \text{ per phase} = 1.914 \times 10^{-4} \text{ F} \quad \text{----- (1 Mark)}$$

∴ Capacitor when connected in delta :-

$$C \text{ per phase} = \frac{Q_c \times 10^3}{3\omega V^2} \quad \text{----- (1 Mark)}$$

$$C \text{ per phase} = \frac{11.644 \times 10^3}{3 \times 2\pi \times 50 \times (440)^2}$$

$$C \text{ per phase} = 6.38 \times 10^{-5} \text{ F} \quad \text{----- (1 Mark)}$$

-----**END**-----